

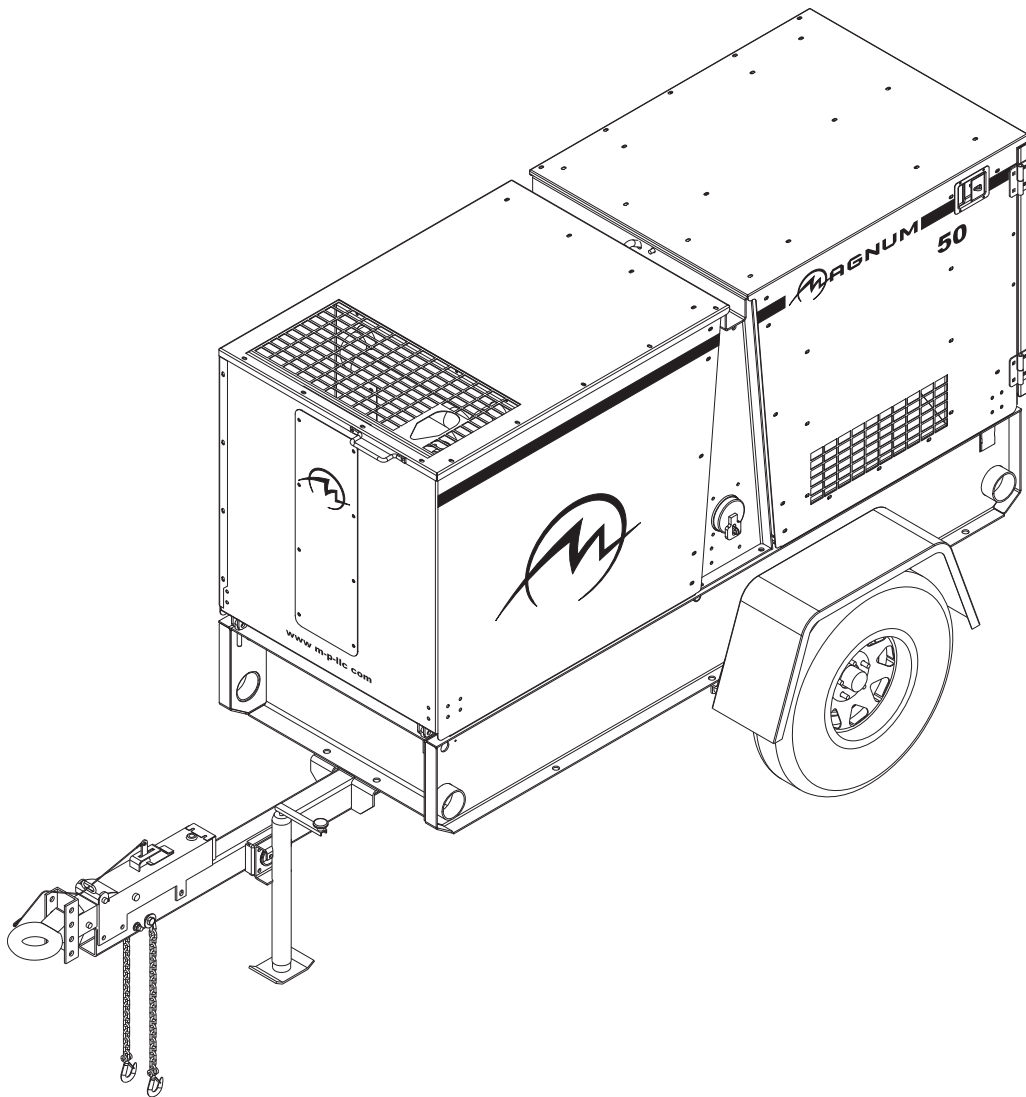

DIESEL GENERATOR
MMG25FHI • MMG35FH • MMG35FHP
MMG45FHK • MMG50FHP • MMG55FH



OPERATING MANUAL

INTRODUCTION

This manual provides information and procedures to safely operate and maintain the engine and generator. For your own safety and protection from physical injury, carefully read, understand, and observe the safety instructions described in this manual. *The information contained in this manual was based on machines in production at the time of publication. Magnum Products LLC reserves the right to change any portion of this information without notice.*

DO NOT MODIFY or use this equipment for any application other than which it was designed for.

Magnum Products LLC recommends that a trained and licensed professional perform all electrical wiring and testing functions. Any wiring should be in compliance with the United States National Electric Code (NEC), state and local codes and Occupational Safety and Health Association (OSHA) guidelines.

Keep a copy of this manual with the unit at all times. Additional copies are available from Magnum Products LLC, or can be found at www.m-p-llc.com. An engine operator's manual was also supplied with the unit at the time of shipment from the factory. The manual provides detailed operation and maintenance procedures for the engine. Additional copies of the engine operators manual are available from the engine manufacturer.

MAGNUM PRODUCTS LLC
215 Power Drive • Berlin, WI 54923
U.S.A.
Phone: 920-361-4442
FAX: 920-361-4416
Toll Free: 1-800-926-9768
www.m-p-llc.com

For technical or parts QUESTIONS, please contact Magnum Products' Customer Support or Technical Support team at 920-361-4442 or toll free at 1-800-926-9768. Please have your serial number available.

To ORDER SERVICE PARTS, please contact the dealer from which you purchased the unit, or call Magnum Products to locate a dealer in your area.

Supplemental information may be available for your unit; when ordering parts ALWAYS check for a supplement that applies to your unit. A supplement may have been provided with your unit and can be found on the Magnum Products LLC website.

Engine Make: _____

Engine Serial Number: _____

Engine Model Number: _____

Generator Make: _____

Generator Model Number: _____

Generator Serial Number: _____

Unit Model Number: _____

Unit Serial Number: _____

▲ WARNING

CALIFORNIA PROPOSITION 65 WARNING: Diesel engine exhaust and some of its constituents are known to the state of California to cause cancer, birth defects and other reproductive harm.

TABLE OF CONTENTS

	Page
INTRODUCTION	2
TABLE OF CONTENTS	3
SAFETY NOTES	4
OPERATING SAFETY	4
ENGINE SAFETY	5
ELECTRICAL SAFETY	5
TOWING SAFETY	6
REPORTING TRAILER SAFETY DEFECTS	6
SAFETY SYMBOL SUMMARY	7
SPECIFICATIONS	8 - 13
UNIT DIMENSIONS	14
UNIT SERIAL NUMBER LOCATIONS	14
COMPONENT LOCATIONS	15
MAIN CONTROL PANEL FEATURES - MMG 25FHI, 35FH, 35FHP, 50FHP, 55FH	16
MAIN CONTROL PANEL FEATURES - MMG 45FHK	18
MAGNUM DIGITAL CONTROLLER (MDC)	20
DIGITAL CONTROLLER FEATURES AND FUNCTIONS	20
GENERATOR MONITORING	21
ENGINE MONITORING	21
FINE VOLTAGE ADJUSTMENT	22
FRONT HOOD OPERATION	23
REAR HOOD OPERATION	24
REAR HOOD OPERATION, CONTINUED	25
PRE - START CHECK LIST	26
MANUAL STARTING OF THE GENERATOR	26
"AUTO" (REMOTE) STARTING OF THE GENERATOR	28
SHUTTING DOWN THE GENERATOR	28
MDC CONTROLLER INFORMATION DISPLAYS, FUNCTIONS AND RESET	29
MAGNUM DIGITAL CONTROLLER (MDC) – GENERATOR OPERATIONAL STATUS	29
MAGNUM DIGITAL CONTROLLER (MDC) - ALARM MANAGEMENT	29
MAGNUM DIGITAL CONTROLLER (MDC)- LIST OF POSSIBLE ALARMS/DESCRIPTIONS	30
MMG ENGINE CONTROLLER	31
ADJUSTING THE DISPLAY BACK LIGHTING	31
MDC CONTROLLER (MDC) – HISTORY	32
RESETTING OF THE "TIME TO SERVICE" REMINDER	33
TROUBLESHOOTING AUTOMATIC SHUT DOWN CONDITIONS	33
GENERATOR OUTPUT CONNECTION LUGS	35
GENERATOR CAM LOCK CONNECTIONS (OPTIONAL)	36
VOLTAGE SELECTOR SWITCH	37
4-POSITION VOLTAGE SELECTOR SWITCH (OPTIONAL)	38
EMERGENCY STOP SWITCH	39
MAIN CIRCUIT BREAKER	39
VOLTAGE REGULATION	39
CUSTOMER CONVENIENCE OUTLETS	40
DERATING FOR ALTITUDE	40
REMOTE START TERMINAL BLOCK	40
ENGINE BREAK-IN REQUIREMENTS	42
DAILY WALK AROUND INSPECTION	42
JOHN DEERE ENGINES ONLY	42
ENGINE AND GENERATOR MAINTENANCE	42
DAILY MAINTENANCE CHECKS	43
LIFTING THE GENERATOR	44
TOWING THE TRAILER	44
TRAILER WHEEL BEARINGS	44
AUXILIARY FUEL TANK OPTION	45
FUEL TRANSFER PUMP OPTION	45
CHECKING GENERATOR DRIVE PLATE TORQUE	45
TRAILER WIRING DIAGRAM	46
ELECTRIC BRAKE WIRING HARNESS	47
AC WIRING DIAGRAM	48
AC WIRING DIAGRAM: MMG45FHK	49
AC WIRING DIAGRAM: 4-POSITION VOLTAGE SELECTOR SWITCH	50
DC WIRING DIAGRAM - JOHN DEERE	51
DC WIRING DIAGRAM - PERKINS	52
DC WIRING DIAGRAM - KUBOTA, ISUZU	53
SERVICE LOG	54

SAFETY NOTES



This is the safety alert symbol. It is used to alert you to potential personal injury hazards. Obey all safety messages that follow this symbol to avoid possible injury or death.

This manual contains DANGERS, WARNINGS, CAUTIONS, NOTICES and NOTES which must be followed to prevent the possibility of improper service, damage to the equipment, personal injury or death. The following formatting options will apply when calling the readers attention to the DANGERS, WARNINGS, CAUTIONS, NOTICES and NOTES.

▲ DANGER

INDICATES A HAZARDOUS SITUATION WHICH, IF NOT AVOIDED, WILL RESULT IN DEATH OR SERIOUS INJURY.

▲ WARNING

Indicates a hazardous situation which, if not avoided, could result in death or serious injury.

▲ CAUTION

Indicates a hazardous situation which, if not avoided, may result in minor or moderate injury.

NOTICE

Indicates a hazardous situation which, if not avoided, may result in property or equipment damage.

Note: Notes contain additional information important to a procedure and will be found within the regular text body of this manual.

OPERATING SAFETY



Before using the generator be sure you read and understand all of the instructions! This equipment was designed for specific applications; **DO NOT** modify or use this equipment for any application other than which it was designed for. Equipment operated improperly or by untrained personnel can be dangerous! Read the operating instructions and familiarize yourself with the location and proper use of all instruments and controls. Inexperienced operators should receive instruction from someone familiar with the equipment before being allowed to operate or set up the generator. The following points should be practiced at all times:

- The area immediately surrounding the generator should be dry, clean, and free of debris.
- **NEVER** start a unit in need of repair.
- Make certain the generator is securely fastened to a good earthen ground before use.
- **NEVER** operate unit on a combustible surface.
- **NEVER** operate the generator if any of the following conditions exist during operation:
 1. Noticeable change in engine speed.
 2. Loss of electrical output.
 3. Equipment connected to the generator overheats.
 4. Sparking occurs.
 5. Engine misfires or there is excessive engine/generator vibration.
 6. Protective covers are loose or missing.
 7. If the ambient air temperature is above 110° F.
- Make sure slings, chains, hooks, ramps, jacks, and other types of lifting devices are attached securely and have enough weight-bearing capacity to lift or hold the equipment safely. Always remain aware of the position of other people around you when lifting the equipment.

ENGINE SAFETY



Internal combustion engines present special hazards during operation and fueling! Failure to follow the safety guidelines described below could result in severe injury or death. Read and follow all safety warnings described in the engine operator's manual. A copy of this manual was supplied with unit when it was shipped from the factory.

- **DO NOT** run engine indoors or in an area with poor ventilation. Diesel engine exhaust contains carbon monoxide, a deadly, odorless and colorless gas which, if inhaled, can cause nausea, fainting or death. Only use this unit outside and away from windows, doors and ventilation equipment.
- **DO NOT** fill fuel tank near an open flame, while smoking, or while engine is running. **DO NOT** fill tank in an enclosed area with poor ventilation.
- **DO NOT** operate with the fuel tank cap loose or missing.
- **DO NOT** touch or lean against hot exhaust pipes or engine cylinders.
- **DO NOT** clean air filter with gasoline or other types of low flash point solvents.
- **DO NOT** remove engine coolant cap while engine is hot.
- **DO NOT** operate the unit without a functional exhaust system. Prolonged exposure to sound levels in excess of 85 dBA can cause permanent hearing loss. Wear hearing protection when working around a running engine.
- Keep hands, feet and loose clothing away from moving parts on the generator and engine.
- Keep area around exhaust pipes and air ducts free of debris to reduce the chance of an accidental fire.
- Batteries contain sulfuric acid which can cause severe injury or death. Sulfuric acid can cause eye damage, burn flesh or eat holes in clothing. Protective eye wear and clothing are necessary when working on or around the battery. Always disconnect the NEGATIVE (-) battery cable from the corresponding terminal before performing any service on the engine or other components.

ELECTRICAL SAFETY



The unit is powered by a generator driven by a diesel engine. While the engine is running, potentially lethal voltages are present at the 120V Ground Fault Circuit Interrupt (GFCI) outlets and the 240V twist lock outlets located on the control panel, and at the connection lugs and cam lock receptacles. Failure to follow the safety guidelines described below could result in severe injury or death.

- Only a qualified and licensed electrician should make connections to the generator.
- **NEVER** wash the unit with any high pressure hoses or power washers.
- **NEVER** start the unit under load. The circuit breakers must be in the "OFF" position when starting the unit in MANUAL mode. The circuit breakers can be in the "ON" position only when started in the AUTO mode. A transfer switch must be used in the AUTO mode to deflect the load upon start up.
- **ALWAYS** disconnect the NEGATIVE (-) battery cable from the corresponding terminal before performing any service on the engine, generator or any other components. Remove the NEGATIVE (-) battery cable from the corresponding terminal if the unit is to be stored or transported.
- **ALWAYS** use extreme caution when servicing this unit in damp conditions. Do not service the unit if your skin or clothing is wet. Do not allow water to collect around the base of the unit.
- **ALWAYS** connect the unit to a good earthen ground before use. Follow any local, state or United States National Electric Code (NEC) guidelines.

TOWING SAFETY



Towing a trailer requires care! Both the trailer and vehicle must be in good condition and securely fastened to each other to reduce the possibility of an accident. Also, some states require that large trailers be registered and licensed. Contact your local Department of Transportation office to check on license requirements for your particular unit.

- Check that the hitch and coupling on the towing vehicle are rated equal to, or greater than, the trailer's "gross vehicle weight rating" (GVWR).
- Check tires on trailer for tread wear, inflation, and condition.
- Inspect the hitch and coupling for wear or damage. **NEVER** tow trailer using defective parts!
- Make sure the trailer hitch and the coupling are compatible. Make sure the coupling is securely fastened to the vehicle.
- Connect safety chains in a crossing pattern under the tongue and attach the breakaway cable **TO THE REAR BUMPER OF THE TOWING VEHICLE**. Do not attach the cable to the trailer hitch.
- Make sure directional and brake lights on the trailer are connected and working properly.
- Check that lug nuts holding wheels are tight and that none are missing.
- Maximum recommended speed for highway towing is 45 mph. Recommended off-road towing speed is not to exceed 10 mph or less depending on terrain.

Before towing the trailer, check that the weight of the trailer is equal across all tires. On trailers with adjustable height hitches, adjust the angle of the trailer tongue to keep the trailer as level as possible. On units equipped with a tandem axle trailer, a large angle between the trailer and tow vehicle will cause more weight to be carried by one axle, which could cause premature wear on the tires and axles and cause potentially unsafe operating conditions.

The trailer is equipped with hydraulic surge brakes or electric surge brakes. Check the operation of the brakes by braking the vehicle at a slow speed before entering traffic. Both the trailer and the vehicle should brake smoothly. If the trailer seems to be pushing, check the level in the surge brake fluid reservoir.

When towing, maintain extra space between vehicles and avoid soft shoulders, curbs and sudden lane changes. If you have not pulled a trailer before, practice turning, stopping, and backing up in an area away from heavy traffic.

A film of grease on the coupler will extend coupler life and eliminate squeaking. Wipe the coupler clean and apply fresh grease each time the trailer is towed.

REPORTING TRAILER SAFETY DEFECTS

If you believe your trailer has a defect which could cause a crash or could cause injury or death, you should immediately inform the National Highway Traffic Safety Administration (NHTSA) in addition to notifying Magnum Products LLC.

If NHTSA receives similar complaints, it may open an investigation; and if it finds that a safety defect exists in a group of vehicles, it may order a recall and remedy campaign. However, NHTSA cannot become involved in individual problem between you, your dealer, or Magnum Products LLC.

To contact NHTSA, you may either call the Auto Safety Hotline toll-free at 1-888-327-4236 (TTY:1-800-424-9153), go to <http://www.safercar.gov>; or write to:

Administrator
NHTSA
1200 New Jersey Avenue S.E.
Washington, DC 20590

You can also obtain other information about motor vehicle safety from <http://www.safercar.gov>.

SAFETY SYMBOL SUMMARY

This equipment has been supplied with numerous safety and operating decals. These decals provide important operating instructions and warn of dangers and hazards. Replace any missing or hard-to-read decals and use care when washing or cleaning the unit. Decal placement and part numbers can be found in the parts section or parts manual included with your unit. Below is a summary of the intended meanings for the symbols used on the decals.

	Safety alert symbol; Used to alert you to potential personal injury hazards.		Asphyxiation hazard; Operate in well ventilated area.
	Hot surface(s) nearby.		Dangerous voltage may be present.
	Belt/entanglement hazard; Keep body parts clear of this area.		Anchor/tie down point.
	Fan hazard; Keep body parts clear of this area.		Isolate generator to prevent electrocution hazard.
	Pinch/crush hazard; Keep body parts clear of this area.		Use clean diesel fuel only.
	Never change position of voltage selector switch while engine is running.		Remove negative battery cable before performing any service on unit.
	Stop engine before making connections.		Read and understand the supplied operator's manual before operating unit.
	Stop engine before fueling.		Unit electrical ground.
	Hearing protection required while operating unit with doors open.		Fire/explosion hazard; Keep open flames away from unit.
	Lift here only.		Burn/scald hazard; Pressurized steam.
	Engine running.		

SPECIFICATIONS

Read this manual carefully before attempting to use this generator. The potential for property damage, personal injury or death exists if this equipment is misused or installed incorrectly. Read all of the manuals included with this unit. Each manual details specific information regarding items such as set up, use and service requirements. **SPECIFICATIONS ARE SUBJECT TO CHANGE WITHOUT NOTICE.**

MAGNUM MODEL	MMG25FHI	MMG25FHI Super Start
Engine		
Make/Brand.....	Isuzu	Isuzu
Model	4LE1NYGV-01	4LE1NYGV-01
Horsepower - prime hp (kW)	32 (24).....	32 (24)
Horsepower - standby hp (kW)	35 (26).....	35 (26)
Operating Speed rpm	1800	1800
Displacement in³ (L)	134 (2.2).....	134 (2.2)
Cylinders - qty	4	4
Fuel Consumption - 100% prime gph (Lph)	1.8 (6.8).....	1.8 (6.8)
Battery Type	Group 24	Group 24
Battery Voltage (Quantity per Unit)	12V (1)	12V (1)
Battery Rating	720 CCA	720 CCA
Generator		
Make/Brand.....	Marathon Electric.....	Marathon Electric
Model	282PSL1505	283PSL1707
Type, Insulation	Brushless, H.....	Brushless, H
Generator Set (Engine/Generator)		
3Ø - Standby kW (kVA)	20 (25).....	22 (27)
Amps - 3Ø Standby 480V (208V) A	30 (69).....	32 (75)
3Ø - Prime kW (kVA)	18 (23).....	19 (24)
Amps - 3Ø Prime 480V (208V) A	28 (64).....	29 (67)
1Ø - Standby kW (kVA)	16 (16).....	21 (21)
Amps - 1Ø Standby - 240V A	67	88
1Ø - Prime kW (kVA)	15 (15).....	19 (19)
Amps - 1Ø Prime - 240V A	63	79
Frequency Hz	60	60
Power Factor.....	1 (1Ø), 0.8 (3Ø).....	1 (1Ø), 0.8 (3Ø)
Sound dB(A) 23 ft @ prime	66	66
Weights		
Dry Weight, Skid Mounted lbs (kg)	2048 (929).....	2139 (970)
Operating Weight, Skid Mounted lbs (kg)	2517 (1142).....	2608 (1183)
Dry Weight, Trailer Mounted* lbs (kg)	2289 (1038).....	2380 (1080)
Operating Weight, Trailer Mounted* lbs (kg)	2758 (1251).....	2849 (1292)
*Standard single axle trailer only. Consult factory for dual axle or custom trailer weights.		
Capacities		
Fuel Tank Volume gal (L)	66 (250).....	66 (250)
Usable Fuel Volume gal (L)	56 (212).....	56 (212)
Coolant (incl. engine) qt (L)	12.0 (11.4).....	12.0 (11.4)
Oil (incl. filter) qt (L)	6.7 (6.3).....	6.7 (6.3)
Maximum Run Time hrs	31	31
AC Distribution		
Circuit Breaker Size	90	90
Voltage Selection	3 Position Switch (lockable).....	3 Position Switch (lockable)
Voltage Regulation	+/- 1%	+/-1%
Voltages Available 1Ø.....	120, 139, 208, 220, 240, 277	120, 139, 208, 220, 240, 277
Voltages Available 3Ø.....	208, 220, 440, 480	208, 220, 440, 480
Trailer		
Number of Axles	1	1
Capacity - Axle Rating lbs (kg)	3500 (1588).....	3500 (1588)
Tire Size in	15	15
Brakes.....	N/A	N/A
Hitch - Standard	2" Ball.....	2" Ball
Maximum Tire Pressure psi	50	50

SPECIFICATIONS

Read this manual carefully before attempting to use this generator. The potential for property damage, personal injury or death exists if this equipment is misused or installed incorrectly. Read all of the manuals included with this unit. Each manual details specific information regarding items such as set up, use and service requirements. **SPECIFICATIONS ARE SUBJECT TO CHANGE WITHOUT NOTICE.**

MAGNUM MODEL	MMG35FH	MMG35FH Super Start
Engine		
Make/Brand.....	John Deere	John Deere
Model	PE4024TF281	PE4024TF281
Horsepower - prime hp (kW)	43 (32).....	43 (32)
Horsepower - standby hp (kW)	48 (36).....	48 (36)
Operating Speed rpm	1800	1800
Displacement in³ (L)	149 (2.4).....	149 (2.4)
Cylinders - qty	4	4
Fuel Consumption - 100% prime gph (Lph)	2.6 (9.8).....	2.6 (9.8)
Battery Type	Group 24	Group 24
Battery Voltage (Quantity per Unit)	12V (1)	12V (1)
Battery Rating	720 CCA	720 CCA
Generator		
Make/Brand.....	Marathon Electric.....	Marathon Electric
Model	283PSL1707	284CSL1542
Type, Insulation	Brushless, H.....	Brushless, H
Generator Set (Engine/Generator)		
3Ø - Standby kW (kVA)	29 (36).....	30 (38)
Amps - 3Ø Standby 480V (208V) A	43 (100).....	46 (105)
3Ø - Prime kW (kVA)	26 (33).....	27 (34)
Amps - 3Ø Prime 480V (208V) A	40 (92).....	41 (94)
1Ø - Standby kW (kVA)	26 (26).....	29 (29)
Amps - 1Ø Standby - 240V A	108	121
1Ø - Prime kW (kVA)	25 (25).....	26 (26)
Amps - 1Ø Prime - 240V A	104	108
Frequency Hz	60	60
Power Factor.....	1 (1Ø), 0.8 (3Ø).....	1 (1Ø), 0.8 (3Ø)
Sound dB(A) 23 ft @ prime	68	68
Weights		
Dry Weight, Skid Mounted lbs (kg)	2196 (996).....	2250 (1021)
Operating Weight, Skid Mounted lbs (kg)	2658 (1206).....	2712 (1230)
Dry Weight, Trailer Mounted* lbs (kg)	2573 (1167).....	2627 (1192)
Operating Weight, Trailer Mounted* lbs (kg)	3035 (1377).....	3089 (1401)
*Standard single axle trailer only. Consult factory for dual axle or custom trailer weights.		
Capacities		
Fuel Tank Volume gal (L)	66 (250).....	66 (250)
Usable Fuel Volume gal (L)	56 (212).....	56 (212)
Coolant (incl. engine) qt (L)	16.0 (15.1).....	16.0 (15.1)
Oil (incl. filter) qt (L)	8.5 (8.0).....	8.5 (8.0)
Maximum Run Time hrs	22	22
AC Distribution		
Circuit Breaker Size	125	125
Voltage Selection	3 Position Switch (lockable).....	3 Position Switch (lockable)
Voltage Regulation	+/- 1%	+/-1%
Voltages Available 1Ø.....	120, 139, 208, 220, 240, 277	120, 139, 208, 220, 240, 277
Voltages Available 3Ø.....	208, 220, 440, 480	208, 220, 440, 480
Trailer		
Number of Axles	1	1
Capacity - Axle Rating lbs (kg)	3500 (1588).....	3500 (1588)
Tire Size in	15	15
Brakes	N/A	N/A
Hitch - Standard	2" Ball	2" Ball
Maximum Tire Pressure psi	50	50

SPECIFICATIONS

Read this manual carefully before attempting to use this generator. The potential for property damage, personal injury or death exists if this equipment is misused or installed incorrectly. Read all of the manuals included with this unit. Each manual details specific information regarding items such as set up, use and service requirements.

SPECIFICATIONS ARE SUBJECT TO CHANGE WITHOUT NOTICE.

MAGNUM MODEL	MMG35FHP	MMG35FHP Super Start
Engine		
Make/Brand.....	Perkins.....	Perkins.....
Model	1103C-33G2.....	1103C-33G2.....
Horsepower - prime hp (kW)	42 (31).....	42 (31).....
Horsepower - standby hp (kW)	46 (34).....	46 (34).....
Operating Speed rpm	1800.....	1800.....
Displacement in³ (L)	201 (3.3).....	201 (3.3).....
Cylinders - qty	3.....	3.....
Fuel Consumption - 100% prime gph (Lph)	2.4 (9.1).....	2.4 (9.1).....
Battery Type.....	Group 24.....	Group 24.....
Battery Voltage (Quantity per Unit)	12V (1).....	12V (1).....
Battery Rating	720 CCA.....	720 CCA.....
Generator		
Make/Brand.....	Marathon Electric.....	Marathon Electric.....
Model	283PSL1707.....	284CSL1542.....
Type, Insulation.....	Brushless, H.....	Brushless, H.....
Generator Set (Engine/Generator)		
3Ø - Standby kW (kVA)	28 (35).....	30 (37).....
Amps - 3Ø Standby 480V (208V) A	42 (97).....	45 (103).....
3Ø - Prime kW (kVA)	26 (32).....	26 (33).....
Amps - 3Ø Prime 480V (208V) A	38 (89).....	40 (92).....
1Ø - Standby kW (kVA)	26 (26).....	28 (28).....
Amps - 1Ø Standby - 240V A	108.....	117.....
1Ø - Prime kW (kVA)	24 (24).....	25 (25).....
Amps - 1Ø Prime - 240V A	100.....	104.....
Frequency Hz	60.....	60.....
Power Factor.....	1 (1Ø), 0.8 (3Ø).....	1 (1Ø), 0.8 (3Ø).....
Sound dB(A) 23 ft @ prime	68.....	68.....
Weights		
Dry Weight, Skid Mounted lbs (kg)	2341 (1062).....	2395 (1086).....
Operating Weight, Skid Mounted lbs (kg)	2810 (1275).....	2864 (1299).....
Dry Weight, Trailer Mounted* lbs (kg)	2718 (1233).....	2772 (1257).....
Operating Weight, Trailer Mounted* lbs (kg)	3187 (1446).....	3241 (1470).....
*Standard single axle trailer only. Consult factory for dual axle or custom trailer weights.		
Capacities		
Fuel Tank Volume gal (L)	66 (250).....	66 (250).....
Usable Fuel Volume gal (L)	56 (212).....	56 (212).....
Coolant (incl. engine) qt (L)	19.0 (17.9).....	19.0 (17.9).....
Oil (incl. filter) qt (L)	7.8 (7.4).....	7.8 (7.4).....
Maximum Run Time hrs	23.....	23.....
AC Distribution		
Circuit Breaker Size	125.....	125.....
Voltage Selection	3 Position Switch (lockable).....	3 Position Switch (lockable).....
Voltage Regulation.....	+/- 1%.....	+/- 1%.....
Voltages Available 1Ø.....	120, 139, 208, 220, 240, 277.....	120, 139, 208, 220, 240, 277.....
Voltages Available 3Ø.....	208, 220, 440, 480.....	208, 220, 440, 480.....
Trailer		
Number of Axles	1.....	1.....
Capacity - Axle Rating lbs (kg)	3500 (1588).....	3500 (1588).....
Tire Size in	15.....	15.....
Brakes.....	N/A.....	N/A.....
Hitch - Standard	2" Ball.....	2" Ball.....
Maximum Tire Pressure psi	50.....	50.....

SPECIFICATIONS

Read this manual carefully before attempting to use this generator. The potential for property damage, personal injury or death exists if this equipment is misused or installed incorrectly. Read all of the manuals included with this unit. Each manual details specific information regarding items such as set up, use and service requirements. **SPECIFICATIONS ARE SUBJECT TO CHANGE WITHOUT NOTICE.**

MAGNUM MODEL	MMG45FHK	MMG45FHK Super Start
Engine		
Make/Brand.....	Kubota.....	Kubota
Model	V3600-T-E3BG.....	V3600-T-E3BG
Horsepower - prime hp (kW)	53 (39).....	53 (39)
Horsepower - standby hp (kW)	58 (43).....	58 (43)
Operating Speed rpm	1800	1800
Displacement in³ (L)	221 (3.6).....	221 (3.6)
Cylinders - qty	4	4
Fuel Consumption - 100% prime gph (Lph)	3.0 (11.4).....	3.0 (11.4)
Battery Type	Group 24	Group 24
Battery Voltage (Quantity per Unit)	12V (1)	12V (1)
Battery Rating	720 CCA	720 CCA
Generator		
Make/Brand.....	Marathon Electric.....	Marathon Electric
Model	284PSL1508	286PSL1701
Type, Insulation	Brushless, H.....	Brushless, H
Generator Set (Engine/Generator)		
3Ø - Standby kW (kVA)	35 (44).....	38 (47)
Amps - 3Ø Standby 480V (208V) A	53 (122).....	57 (130)
3Ø - Prime kW (kVA)	33 (41).....	34 (43)
Amps - 3Ø Prime 480V (208V) A	49 (114).....	52 (119)
1Ø - Standby kW (kVA)	33 (33).....	36 (36)
Amps - 1Ø Standby - 240V A	138	150
1Ø - Prime kW (kVA)	30 (30).....	33 (33)
Amps - 1Ø Prime - 240V A	125	138
Frequency Hz	60	60
Power Factor.....	1 (1Ø), 0.8 (3Ø).....	1 (1Ø), 0.8 (3Ø)
Sound dB(A) 23 ft @ prime	68	68
Weights		
Dry Weight, Skid Mounted lbs (kg)	2329 (1056).....	2524 (1145)
Operating Weight, Skid Mounted lbs (kg)	3082 (1398).....	3277 (1486)
Dry Weight, Trailer Mounted* lbs (kg)	2853 (1294).....	3048 (1383)
Operating Weight, Trailer Mounted* lbs (kg)	3606 (1636).....	3801 (1724)
*Standard single axle trailer only. Consult factory for dual axle or custom trailer weights.		
Capacities		
Fuel Tank Volume gal (L)	106 (401).....	106 (401)
Usable Fuel Volume gal (L)	95 (360).....	95 (360)
Coolant (incl. engine) qt (L)	17.5 (16.6).....	17.5 (16.6)
Oil (incl. filter) qt (L)	14.5 (13.7).....	14.5 (13.7)
Maximum Run Time hrs	35	35
AC Distribution		
Circuit Breaker Size	200	200
Voltage Selection	3 Position Switch (lockable).....	3 Position Switch (lockable)
Voltage Regulation	+/- 1%	+/-1%
Voltages Available 1Ø.....	120, 139, 208, 220, 240, 277	120, 139, 208, 220, 240, 277
Voltages Available 3Ø.....	208, 220, 440, 480	208, 220, 440, 480
Trailer		
Number of Axles	1	1
Capacity - Axle Rating lbs (kg)	5000 (2268).....	5000 (2268)
Tire Size in	15	15
Brakes.....	Surge	Surge
Hitch - Standard	2" Ball.....	2" Ball
Maximum Tire Pressure psi	65	65

SPECIFICATIONS

Read this manual carefully before attempting to use this generator. The potential for property damage, personal injury or death exists if this equipment is misused or installed incorrectly. Read all of the manuals included with this unit. Each manual details specific information regarding items such as set up, use and service requirements. **SPECIFICATIONS ARE SUBJECT TO CHANGE WITHOUT NOTICE.**

MAGNUM MODEL	MMG50FHP	MMG50FHP Super Start
Engine		
Make/Brand.....	Perkins.....	Perkins.....
Model.....	1104C-44G2.....	1104C-44G2.....
Horsepower - prime hp (kW)	71 (53).....	71 (53).....
Horsepower - standby hp (kW)	64 (48).....	64 (48).....
Operating Speed rpm	1800.....	1800.....
Displacement in³ (L)	269 (4.4).....	269 (4.4).....
Cylinders - qty	4.....	4.....
Fuel Consumption - 100% prime gph (Lph)	3.2 (12.1).....	3.2 (12.1).....
Battery Type.....	Group 24.....	Group 24.....
Battery Voltage (Quantity per Unit)	12V (1).....	12V (1).....
Battery Rating	720 CCA.....	720 CCA.....
Generator		
Make/Brand.....	Marathon Electric.....	Marathon Electric.....
Model.....	286PSL1701.....	287PSL1702.....
Type, Insulation.....	Brushless, H.....	Brushless, H.....
Generator Set (Engine/Generator)		
3Ø - Standby kW (kVA)	47 (59).....	47 (59).....
Amps - 3Ø Standby 480V (208V) A	71 (164).....	71 (164).....
3Ø - Prime kW (kVA)	43 (54).....	42 (53).....
Amps - 3Ø Prime 480V (208V) A	65 (150).....	64 (147).....
1Ø - Standby kW (kVA)	45 (45).....	45 (45).....
Amps - 1Ø Standby - 240V A	188.....	188.....
1Ø - Prime kW (kVA)	41 (41).....	41 (41).....
Amps - 1Ø Prime - 240V A	167.....	171.....
Frequency Hz	60.....	60.....
Power Factor.....	1 (1Ø), 0.8 (3Ø).....	1 (1Ø), 0.8 (3Ø).....
Sound dB(A) 23 ft @ prime	68.....	68.....
Weights		
Dry Weight, Skid Mounted lbs (kg)	2793 (1267).....	2863 (1299).....
Operating Weight, Skid Mounted lbs (kg)	3468 (1573).....	3538 (1605).....
Dry Weight, Trailer Mounted* lbs (kg)	3317 (1505).....	3387 (1536).....
Operating Weight, Trailer Mounted* lbs (kg)	3992 (1811).....	4062 (1842).....
*Standard single axle trailer only. Consult factory for dual axle or custom trailer weights.		
Capacities		
Fuel Tank Volume gal (L)	106 (401).....	106 (401).....
Usable Fuel Volume gal (L)	95 (360).....	95 (360).....
Oil (incl. filter) qt (L)	9.0 (8.5).....	9.0 (8.5).....
Maximum Run Time hrs	30.....	30.....
AC Distribution		
Circuit Breaker Size	225.....	225.....
Voltage Selection	3 Position Switch (lockable).....	3 Position Switch (lockable).....
Voltage Regulation	+/- 1%.....	+/-1%.....
Voltages Available 1Ø.....	120, 139, 208, 220, 240, 277.....	120, 139, 208, 220, 240, 277.....
Voltages Available 3Ø.....	208, 220, 440, 480.....	208, 220, 440, 480.....
Trailer		
Number of Axles	1.....	1.....
Capacity - Axle Rating lbs (kg)	5000 (2268).....	5000 (2268).....
Tire Size in	15.....	15.....
Brakes.....	Surge.....	Surge.....
Hitch - Standard	2" Ball.....	2" Ball.....
Maximum Tire Pressure psi	65.....	65.....

SPECIFICATIONS

Read this manual carefully before attempting to use this generator. The potential for property damage, personal injury or death exists if this equipment is misused or installed incorrectly. Read all of the manuals included with this unit. Each manual details specific information regarding items such as set up, use and service requirements. **SPECIFICATIONS ARE SUBJECT TO CHANGE WITHOUT NOTICE.**

MAGNUM MODEL	MMG55FH	MMG55FH Super Start
Engine		
Make/Brand.....	John Deere	John Deere
Model	PE5030TF270	PE5030TF270
Horsepower - prime hp (kW)	72 (54).....	72 (54)
Horsepower - standby hp (kW)	80 (60).....	80 (60)
Operating Speed rpm	1800	1800
Displacement in³ (L)	186 (3.0).....	186 (3.0)
Cylinders - qty	5.....	5
Fuel Consumption - 100% prime gph (Lph)	4.0 (15.1).....	4.0 (15.1)
Battery Type	Group 24	Group 24
Battery Voltage (Quantity per Unit)	12V (1)	12V (1)
Battery Rating	720 CCA	720 CCA
Generator		
Make/Brand.....	Marathon Electric.....	Marathon Electric
Model	286PSL1701	287PSL1702
Type, Insulation	Brushless, H.....	Brushless, H
Generator Set (Engine/Generator)		
3Ø - Standby kW (kVA)	52 (65).....	52 (65)
Amps - 3Ø Standby 480V (208V) A	78 (180).....	78 (180)
3Ø - Prime kW (kVA)	47 (59).....	47 (59)
Amps - 3Ø Prime 480V (208V) A	71 (164).....	71 (164)
1Ø - Standby kW (kVA)	49 (49).....	50 (50)
Amps - 1Ø Standby - 240V A	204	208
1Ø - Prime kW (kVA)	45 (45).....	45 (45)
Amps - 1Ø Prime - 240V A	188	188
Frequency Hz	60	60
Power Factor.....	1 (1Ø), 0.8 (3Ø).....	1 (1Ø), 0.8 (3Ø)
Sound dB(A) 23 ft @ prime	68	68
Weights		
Dry Weight, Skid Mounted lbs (kg)	2570 (1170).....	2640 (1197)
Operating Weight, Skid Mounted lbs (kg)	3255 (1480).....	3325 (1508)
Dry Weight, Trailer Mounted* lbs (kg)	3090 (1400).....	3160 (1433)
Operating Weight, Trailer Mounted* lbs (kg)	3770 (1710).....	3840 (1742)
*Standard single axle trailer only. Consult factory for dual axle or custom trailer weights.		
Capacities		
Fuel Tank Volume gal (L)	106 (401).....	106 (401)
Usable Fuel Volume gal (L)	95 (360).....	95 (360)
Coolant (incl. engine) qt (L)	18.0 (17.0).....	18.0 (17.0)
Oil (incl. filter) qt (L)	9.0 (8.5).....	9.0 (8.5)
Maximum Run Time hrs	24	24
AC Distribution		
Circuit Breaker Size	225	225
Voltage Selection	3 Position Switch (lockable).....	3 Position Switch (lockable)
Voltage Regulation	+/- 1%	+/-1%
Voltages Available 1Ø.....	120, 139, 208, 220, 240, 277	120, 139, 208, 220, 240, 277
Voltages Available 3Ø.....	208, 220, 440, 480	208, 220, 440, 480
Trailer		
Number of Axles	1	1
Capacity - Axle Rating lbs (kg)	5000 (2268).....	5000 (2268)
Tire Size in	15	15
Brakes.....	Surge	Surge
Hitch - Standard	2" Ball.....	2" Ball
Maximum Tire Pressure psi	65	65

UNIT DIMENSIONS

Read this manual carefully before attempting to use this generator. The potential for property damage, personal injury or death exists if this equipment is misused or installed incorrectly. Read all of the manuals included with this unit. Each manual details specific information regarding items such as set up, use and service requirements. **SPECIFICATIONS ARE SUBJECT TO CHANGE WITHOUT NOTICE.**

Dimensions (L x W x H)

Skid Mounted in (m) 95 x 35 x 52 (2.41 x 0.89 x 1.32)
 Trailer Mounted in (m) 150 x 57 x 67 (3.81 x 1.45 x 1.70)

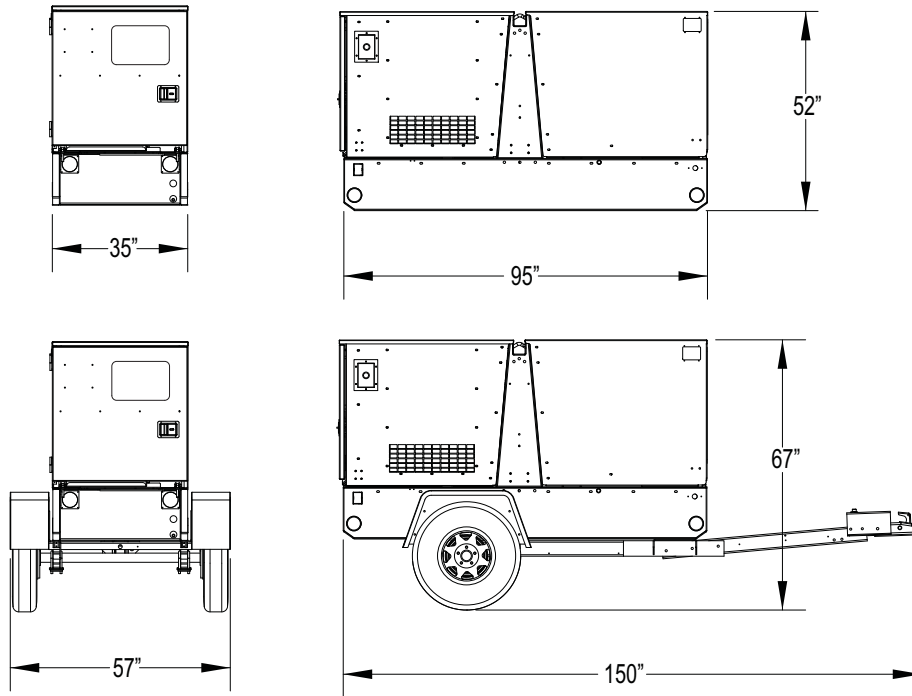

UNIT SERIAL NUMBER LOCATIONS

Refer to the locations illustrated below to find the unit ID tag, V.I.N. tag and trailer ID tag on your unit. Important information, such as the unit serial number, model number and Vehicle Identification Number (V.I.N.) for your trailer are found on these tags. Record the information from these tags, so it is available if the tags are lost or damaged. When ordering parts or requesting technical service information, you may be asked to specify this information.

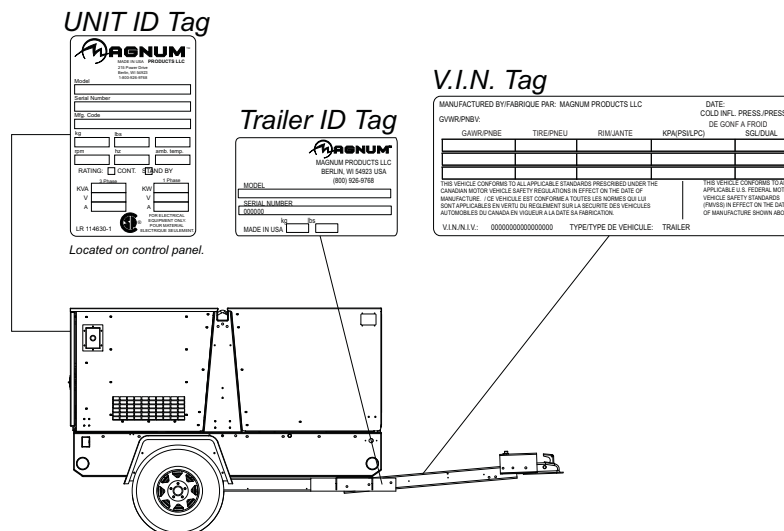

COMPONENT LOCATIONS

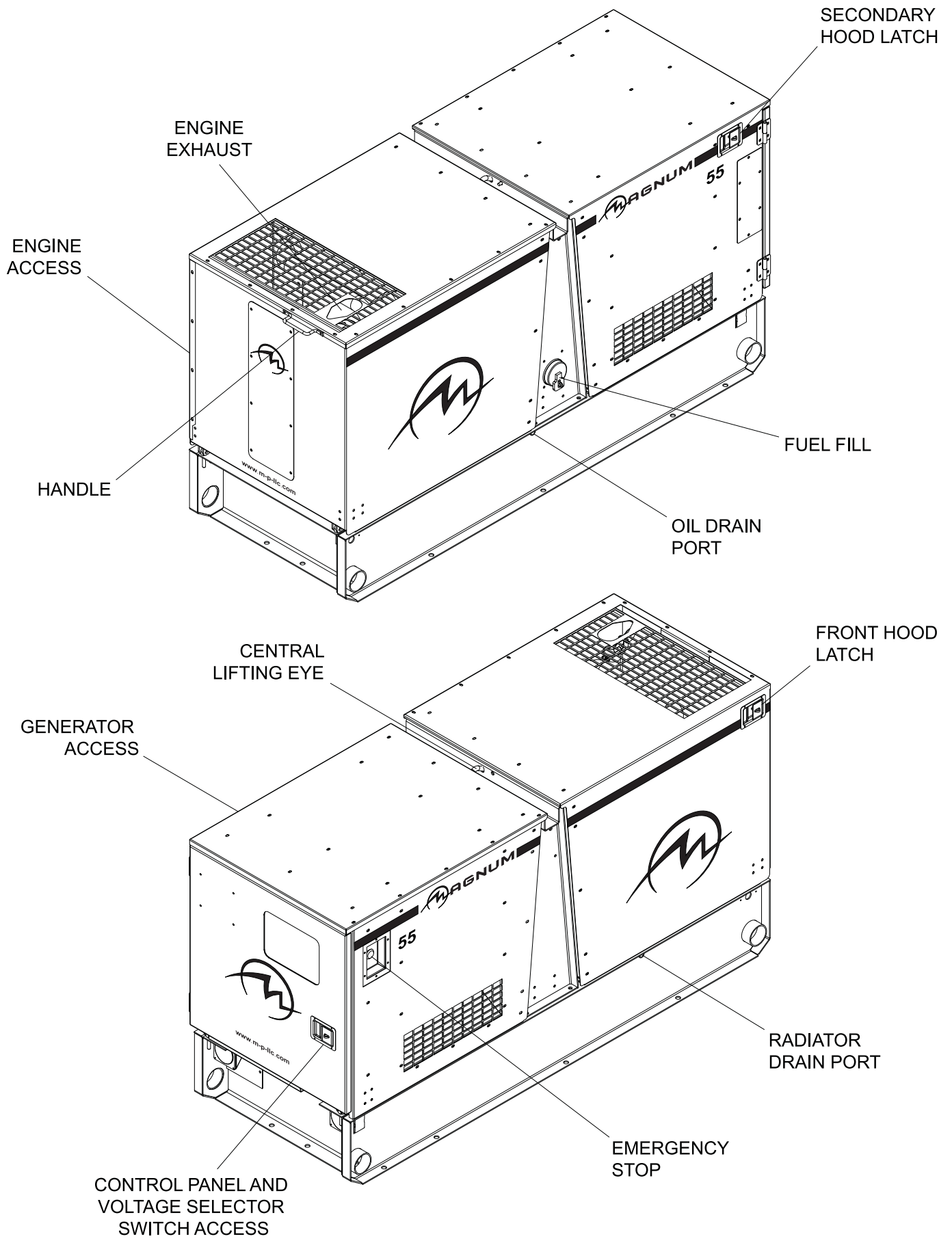

MAIN CONTROL PANEL FEATURES - MMG 25FH, 35FH, 35FHP, 50FHP, 55FH

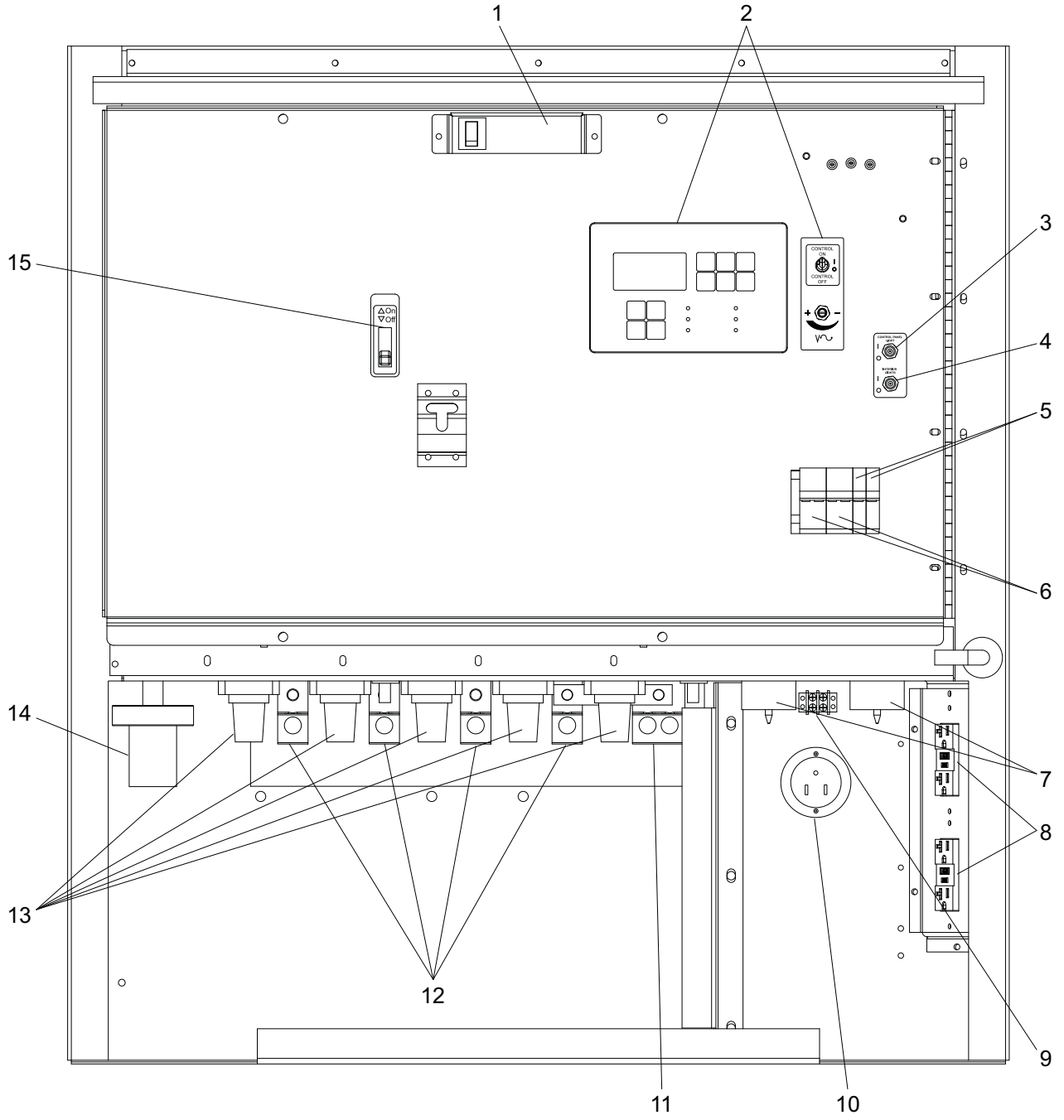

1. **CONTROL PANEL LIGHT (Optional)**
2. **MAGNUM DIGITAL CONTROLLER (MDC):** Controls and monitors engine and generator operation. See page 20 for more information.
3. **CONTROL PANEL LIGHT SWITCH (Optional):** Operates optional control panel light.
4. **INTERIOR LIGHT SWITCH (Optional):** Operates optional interior light.
5. **20A CIRCUIT BREAKERS:** Disconnects power to the 120V GFCI outlets.
6. **50A CIRCUIT BREAKERS:** Disconnects power to the 120/240V twist-lock outlets.
7. **120/240V TWIST-LOCK CONVENIENCE OUTLETS:** Allow for connecting additional loads or equipment to the generator.
8. **120V GFCI DUPLEX CONVENIENCE OUTLETS:** Allow for connecting additional loads or equipment to the generator.
9. **REMOTE START TERMINAL BLOCK:** Allows the generator to be started from a remote location with a dry-contact closure switch when the generator is used for standby or remote power.
10. **ENGINE ACCESSORY CONNECTION:** Powers the battery charger and other engine accessories.
11. **GENERATOR GROUND CONNECTION LUG:** Allows connection to a good earthen ground per any local, state or National Electric Code (NEC) guidelines before starting the generator.
12. **GENERATOR OUTPUT CONNECTION LUGS:** Allow appropriate loads to be wired directly to the generator.
13. **CAM LOCK CONNECTORS (Optional):** Series 16 Taper Nose 400A, 600V cam locks are connected here. See page 36 for more information.
14. **VOLTAGE SELECTOR SWITCH:** Mechanically changes the connections between the generator output leads and the connection lugs and the optional cam lock connectors on the main control panel.
15. **MAIN CIRCUIT BREAKER:** Disconnects power to the connection lugs and the optional cam lock connectors (items 11-13). It WILL NOT disconnect power to the convenience outlets when the engine is running.

MAIN CONTROL PANEL FEATURES - MMG 45FHK

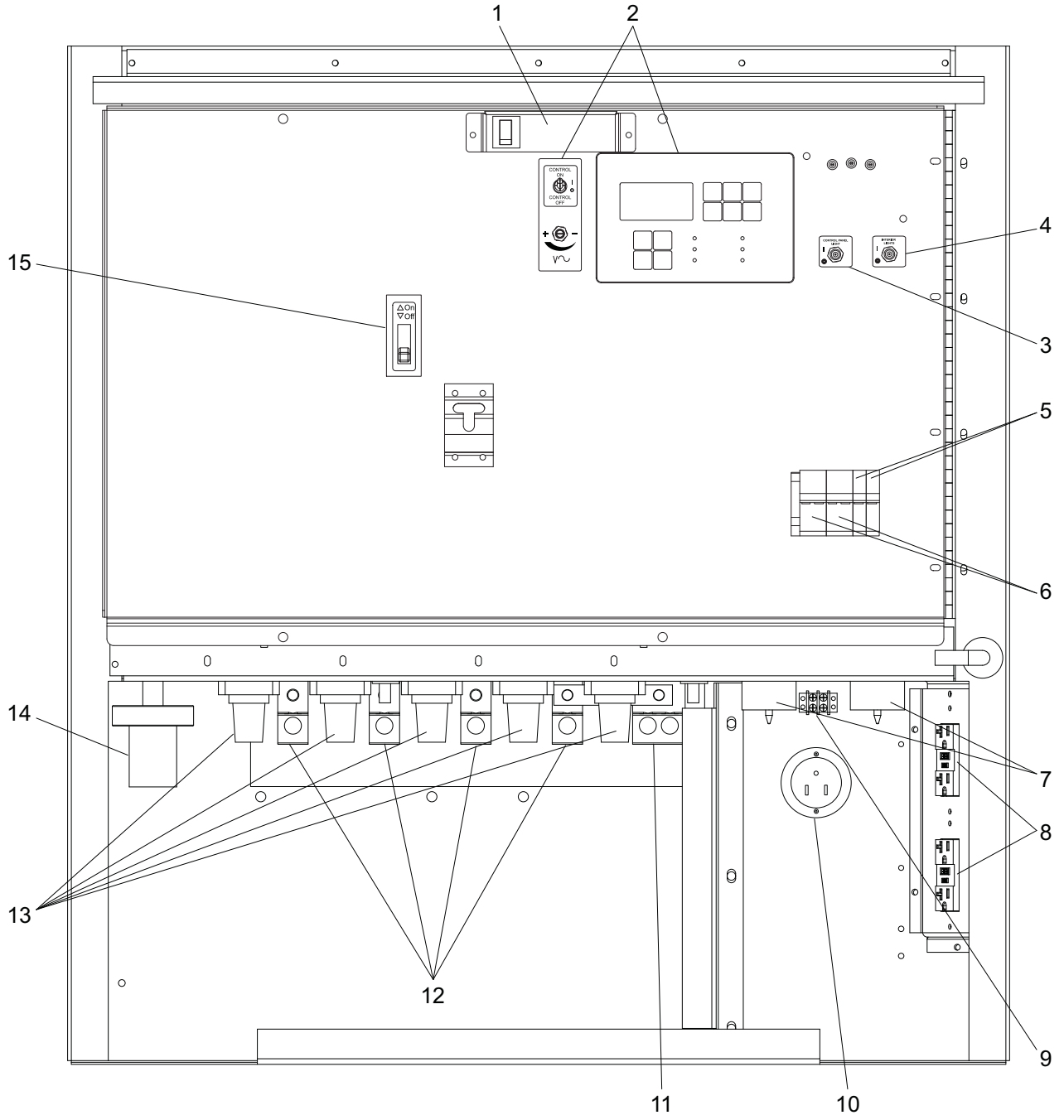

1. **CONTROL PANEL LIGHT (Optional)**
2. **MAGNUM DIGITAL CONTROLLER (MDC):** Controls and monitors engine and generator operation. See page 20 for more information.
3. **CONTROL PANEL LIGHT SWITCH (Optional):** Operates optional control panel light.
4. **INTERIOR LIGHT SWITCH (Optional):** Operates optional interior light.
5. **20A CIRCUIT BREAKERS:** Disconnects power to the 120V GFCI outlets.
6. **50A CIRCUIT BREAKERS:** Disconnects power to the 120/240V twist-lock outlets.
7. **120/240V TWIST-LOCK CONVENIENCE OUTLETS:** Allow for connecting additional loads or equipment to the generator.
8. **120V GFCI DUPLEX CONVENIENCE OUTLETS:** Allow for connecting additional loads or equipment to the generator.
9. **REMOTE START TERMINAL BLOCK:** Allows the generator to be started from a remote location with a dry-contact closure switch when the generator is used for standby or remote power.
10. **ENGINE ACCESSORY CONNECTION:** Powers the battery charger and other engine accessories.
11. **GENERATOR GROUND CONNECTION LUG:** Allows connection to a good earthen ground per any local, state or National Electric Code (NEC) guidelines before starting the generator.
12. **GENERATOR OUTPUT CONNECTION LUGS:** Allow appropriate loads to be wired directly to the generator.
13. **CAM LOCK CONNECTORS (Optional):** Series 16 Taper Nose 400A, 600V cam locks are connected here. See page 36 for more information.
14. **VOLTAGE SELECTOR SWITCH:** Mechanically changes the connections between the generator output leads and the connection lugs and the optional cam lock connectors on the main control panel.
15. **MAIN CIRCUIT BREAKER:** Disconnects power to the connection lugs and the optional cam lock connectors (items 11-13). It WILL NOT disconnect power to the convenience outlets when the engine is running.

MAGNUM DIGITAL CONTROLLER (MDC)

The Magnum Digital Controller (MDC) is an enhanced digital generator controller used to start, stop and monitor the operation of the generator and the engine. The controller constantly monitors vital generator and engine functions for a number of pre-programmed alarm and fault conditions. When a fault condition occurs, the engine will shut down automatically and the Liquid Crystal Display (LCD) window will display the fault that caused the shut down; to resume operation the fault condition must be resolved. The controller has the ability to provide the display readout in English and Spanish; other languages are available. A screen print out of the display screen is also available. This controller also records a “History” of the unit’s performance which may be viewed at any time and will not be removed or lost when the controller is powered down.

The MDC panel consists of five sections, including: the “CONTROL ON/OFF” Toggle Switch and Fine Voltage Adjustment Screw; the “OPERATION” keypad; the LCD window; the “DIAGNOSTICS” keypad; and the “STATUS” Light Emitting Diodes (LED’s).

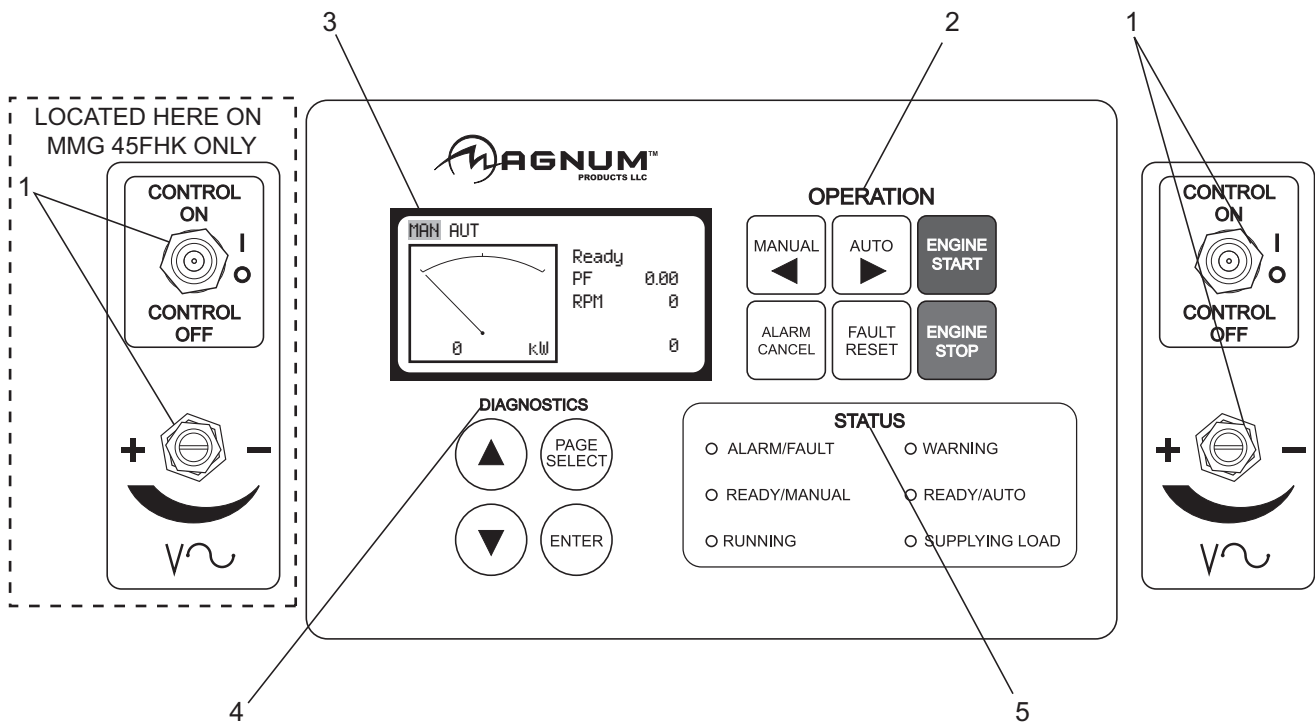

DIGITAL CONTROLLER FEATURES AND FUNCTIONS

1. The “CONTROL ON/OFF” Toggle Switch and Fine Voltage Adjustment Screw
 - “CONTROL ON/OFF” Toggle Switch: This toggle switch powers-up the control panel and the controller.
 - Fine Voltage Adjustment Screw: This screw may be adjusted to set the generator output voltage after the voltage selector switch has been changed from one phase to another. This adjustment must be accomplished within 45 seconds.
2. The “OPERATION” Keypad
 - “ENGINE START” Button: The Power Screen Display must be in the “MAN” mode in the upper left corner of the LCD window display and the “Ready/Manual” LED lit in the “Status” portion of the controller. Press the green “ENGINE START” button to start the unit.
 - “ENGINE STOP” Button: Press the red “ENGINE STOP” button to shut down the unit and start the “Stop Value” timer.
 - “MANUAL ◀” Button: Press this button to change from the Automatic (remote) starting mode to Manual starting mode.
 - “AUTO ▶” Button: Press this button to change from Manual starting mode to Automatic (remote) starting mode.
 - “ALARM CANCEL” Button: When an alarm is activated, press this button to silence or cancel the alarm.

- **“FAULT RESET” Button:** Press this button to clear the fault from the LCD window after the fault has been corrected. Press “FAULT RESET” and “ENTER” to clear the John Deere ECU Alarm List Codes.

3. The Liquid Crystal Display (LCD)

- This window will toggle between the Generator Display Screen and the Engine Display Screen upon start-up of the unit. By viewing these screens, the operator will be able to monitor both the engine and generator status while the unit is running.

4. The “DIAGNOSTICS” Keypad

- **“▲” Scroll-Up Button:** Press this button to scroll-up within the LCD window.
- **“▼” Scroll-Down Button:** Press this button to scroll-down within the LCD window.
- **“PAGE SELECT” Button:** Pressing this button will select the next display screen.
- **“ENTER” Button:** Pressing this button will place you inside the particular display to review the generators pre programmed setpoints or parameters.

5. The “STATUS” Light Emitting Diodes (LED’s)

- These six LED’s will illuminate to display the current operational status of the generator;
 - Alarm/Fault: Indicates active or inactive alarms, but not reset shut down alarms.
 - Warning: Indicates an active or inactive alarm, or a warning alarm that has not been reset.
 - Ready/Manual: Indicates the controller is ready to start and in the manual mode.
 - Ready/Auto: Indicates the unit is in the “AUTO” mode ready for the remote start signal.
 - Running: Indicates the unit is running.
 - Supplying Load: Indicates a load is being applied to the generator.

GENERATOR MONITORING

Generator information is shown on the Liquid Crystal Display (LCD) window in a toggling manner with the Engine information after the first 60 seconds of operation, then every five seconds thereafter. The generator display screen will show frequency, line to neutral voltage, line to line voltage and amperage.

Note: When loading the generator, it is important to observe the amperage to determine the load balance on each line of the generator. Minor load unbalances, usually five percent or less, will not cause any particular problems. Every effort should be made to distribute the load equally between all lines.

- **Hertz:** Displays output frequency.
- **Generator Output Voltage:** Line to Neutral display, single phase (1Ø).
- **Generator Output Voltage:** Line to Line display, 3 phase (3Ø).
- **Amps:** Displays the AC output amperage produced by the generator.

GENERATOR DISPLAY SCREEN

Gen freq			60.0Hz
L1N	120V	L12	208V
L2N	120V	L23	208V
L3N	120V	L31	208V
A	226	222	223

ENGINE DISPLAY SCREEN

Oil Press	49 psi
Engine Temp	183°F
Fuel Level	83%
Ubat	13.4V

ENGINE MONITORING

Engine information is shown on the Liquid Crystal Display (LCD) window in a toggling manner with the Generator information after the first 60 seconds of operation and then every five seconds thereafter. Fine Voltage Adjustment

Upon start-up of the generator, the “Running” screen of the Magnum Digital Controller (MDC) will display “SENSING” and will countdown from 45 seconds to “0” Zero. This is a safety feature of the controller to protect the generator from over or under voltage upon start-up.

“SENSING” is a 45 second time delay and count down process before the MDC records the generator nominal output voltage. This nominal generator voltage is then compared to the current set point voltage of the voltage selector switch. If the nominal voltage recorded by the controller is greater than or lower than the current set point voltage of the voltage selector switch setting by 10% or more, the controller will shut the generator down automatically. The display will read: Wrn VG1 or 2 or 3 Under/Over and/or Sd Vg1 or 2 or 3 Under/Over. This means the controller warned (“Wrn”) or shut down (“Sd”) the unit due to an output voltage irregularity.

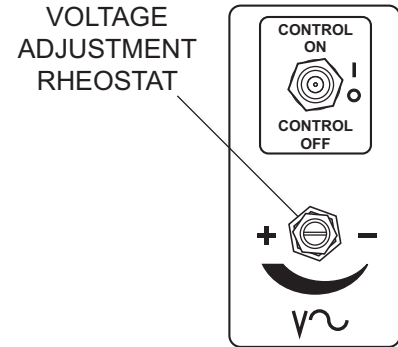

The output voltage of the generator may be adjusted after the generator is running by using the fine voltage adjustment screw. The adjusting screw is located directly below the “CONTROL ON/OFF” toggle switch on the control panel. This screw turns a rheostat that will provide an increase (“+”) or a decrease (“-”) in the generator output voltage as displayed on the Power Display Screen on the control panel. If the voltage is increased or decreased too fast or too slow, the unit will automatically shut down. This adjustment needs to be made within the 45 second delay and countdown to “0” Zero period.

To adjust the output voltage, check the output voltage on the Liquid Crystal Display (LCD) window labeled Gen freq & Hz. Look at the L1N voltage or the L12 voltage on the display. The generator nominal output voltage should be within 10% of the voltage rating on the voltage selector switch.

To adjust the output voltage loosen the lock nut at the base of the screw and turn the screw in the desired direction until the required voltage shown on the LCD window matches the stated voltage on the voltage selector switch.

For Example: With the voltage selector switch set to “208/120V” 3 Phase position, the voltage displayed on the Gen freq & Hz screen must be within $\pm 10\%$ of the 208/120 position (188-228 V Line to Line / 108-132 V Line to Neutral).

Note: Each time the voltage selector switch is changed from one setting to another, an adjustment will need to be made to the fine voltage using this adjustment screw.

FRONT HOOD OPERATION

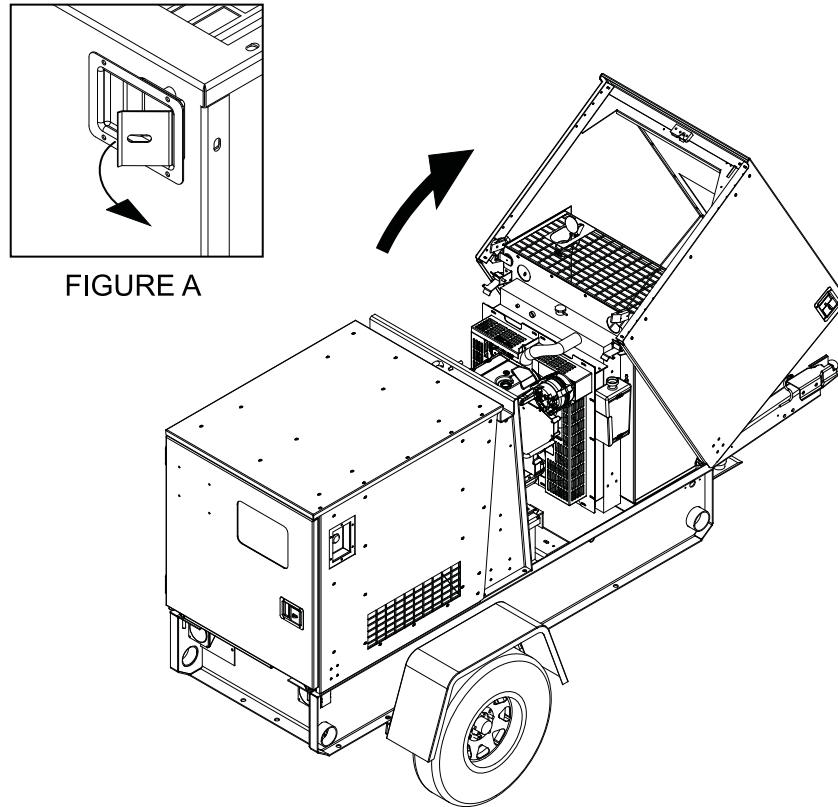

FIGURE A

▲ WARNING

Stay clear of hood and lift structure when opening and closing generator hoods. Personal injury may result.

TO OPEN THE FRONT HOOD:

1. With your right hand, grip the handle located on the upper right side of the front panel.
2. With your left hand, pull the hood latch located on the upper corner of the left hood side (see Figure A). Tilt the hood open until it contacts the bulkhead panel.

▲ CAUTION

Generator hoods are heavy. Use caution when opening or closing.

TO CLOSE THE FRONT HOOD:

1. Make sure the skid is free of debris and all personnel are clear of unit.
2. Slowly push hood forward and allow it to close firmly to ensure the hood latch is engaged.
3. Verify the hood is securely closed by attempting to open without pulling the hood latch.

REAR HOOD OPERATION

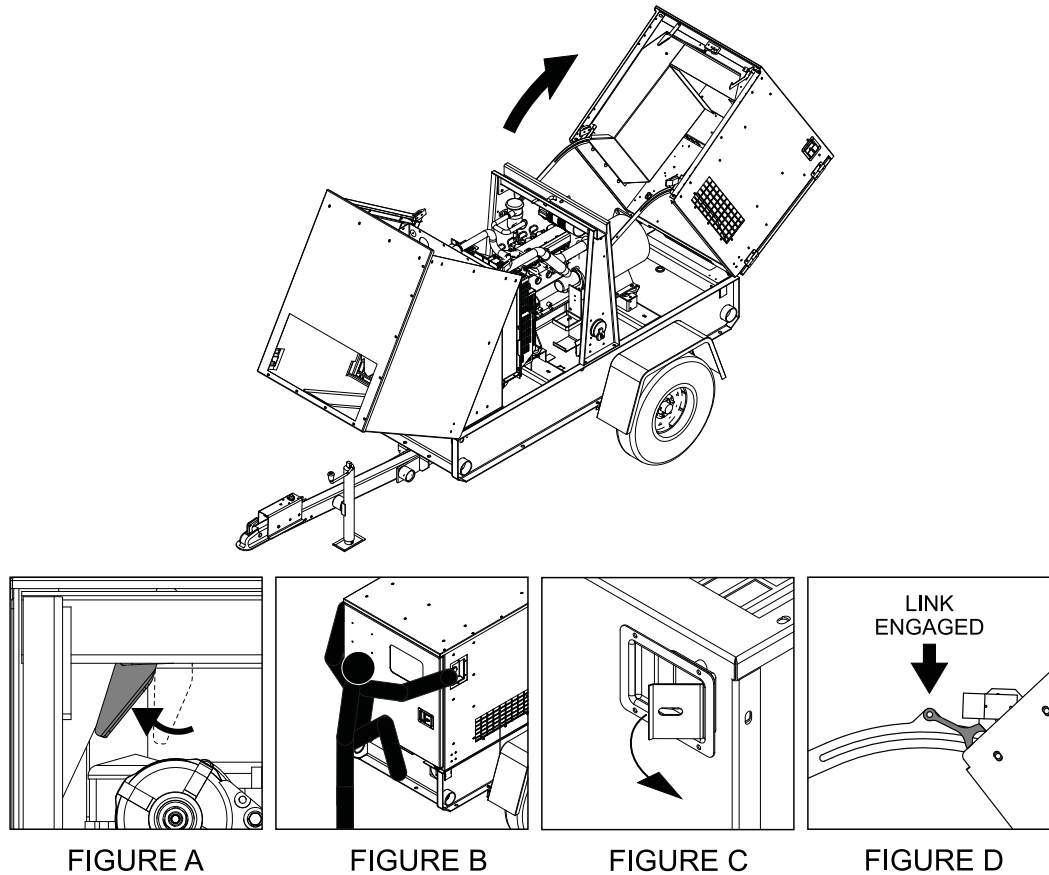

▲ WARNING

Stay clear of hood and lift structure when opening and closing generator hoods. Personal injury may result.

TO OPEN THE REAR HOOD:

1. Open front hood.
2. Verify that the control door is completely closed and secure.
3. Pull lever located under lift structure to release the primary hood latch (see Figure A).
4. Proceed to rear of unit to release the secondary hood latch and tilt the hood open (see Figure B).
 - A. With your right hand, grip the lip of the emergency stop panel on the right side of the unit.
 - B. With your left hand, pull the hood latch located on the upper corner of the left hood side (see Figure C). Tilt the hood completely open; travel is limited by two metal guide straps.

▲ CAUTION

Generator hoods are heavy. Use caution when opening or closing.

5. Verify the red safety link is engaged and undamaged. This link is located on the left side metal guide strap (see Figure D).

▲ WARNING

If the red safety link is not properly engaged, unintentional closing of the hood could result, causing personal injury or equipment damage.

REAR HOOD OPERATION, CONTINUED

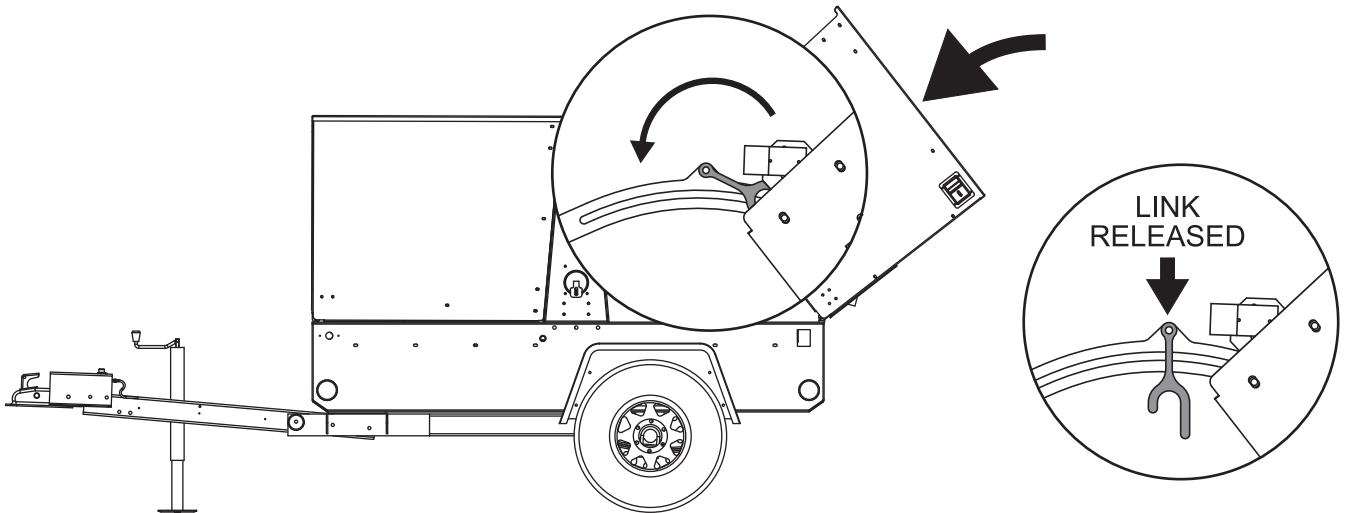

⚠ WARNING

**Stay clear of hood and lift structure when opening and closing generator hoods.
Personal injury may result.**

TO CLOSE THE REAR HOOD:

1. Make sure the skid is free of debris and all personnel are clear of unit.
2. Verify that the control door is completely closed and secure.
3. Release the red safety link located on the left side metal guide strap by rotating the link counterclockwise.

⚠ CAUTION

Generator hoods are heavy. Use caution when opening or closing.

4. Slowly push hood forward and allow it to close firmly to ensure the hood latches have engaged.
5. Verify the hood is securely closed by attempting to open without releasing the hood latches.

NOTICE

Failure to release the safety link could result in damage to the link or other components.

PRE - START CHECK LIST

Before starting the generator, carefully read the pre-start check list. Make sure that all of the items are checked before trying to start the generator. This check list applies to both manual and remote starting of the generator.

- Read and understand *ALL* safety sections at the beginning of this manual.
- Make sure the control ON/OFF toggle switch is in the OFF “O” position.
- Make sure that the circuit breakers (main and convenience) are switched OFF “O”.
- Check that the generator is properly grounded to a good earthen ground per any local and NEC regulations.
- Check all electrical connections at the connection lugs and cam lock receptacles (if equipped). Are they wired correctly?
- Are the connection lugs tight?
- Check the voltage selector switch and make sure that it is set to the desired voltage.
- Is the generator sitting level?
- Thoroughly check for any water inside the unit, on or near the generator. Dry the unit before starting.
- Check oil, coolant and fuel levels and engine battery connections.
- Check engine fan belt tension and condition.
- Check engine fan belt guard.
- Check engine exhaust system for loose or rusted components.
- Check radiator and surrounding shroud for debris.
- Are any of the generator covers loose or missing?
- Are all preventative maintenance procedures up to date?
- Check that the battery disconnect switch is on, if equipped.

MANUAL STARTING OF THE GENERATOR

1. Move the control ON/OFF toggle switch to the “CONTROL ON / I” position.

▲ DANGER

CARBON MONOXIDE: USING A GENERATOR INDOORS CAN KILL YOU IN MINUTES!

2. The Liquid Crystal Display (LCD) window will quickly display system information, all Light Emitting Diodes (LED's) will flash.

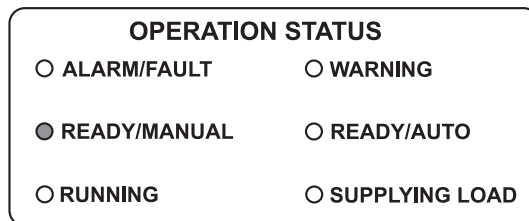
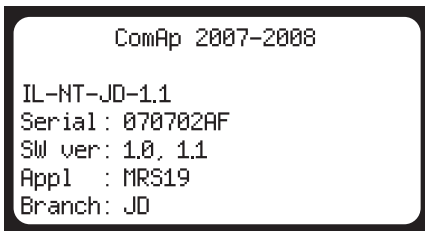

3. The LCD window will indicate “MAN” (manual) mode and “Ready”. The Ready/Manual LED will be lit.

Note: The unit must be in the “MAN” Mode with the Ready/Manual LED lit to start the unit.

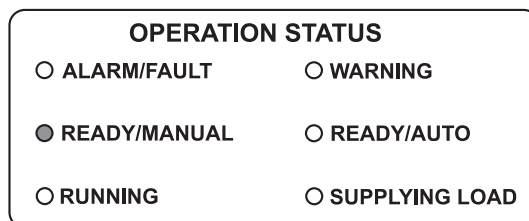
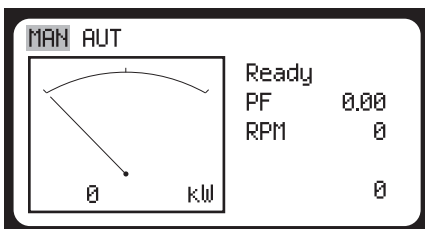

4. Press the green “ENGINE START” button. The Prestart (Preheat) screen will be displayed (if equipped) and a countdown will begin from 20 seconds to 0.

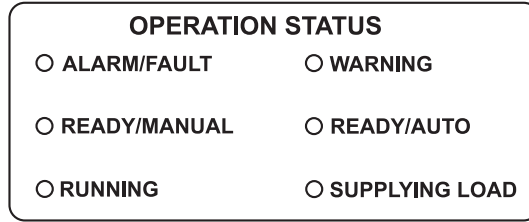
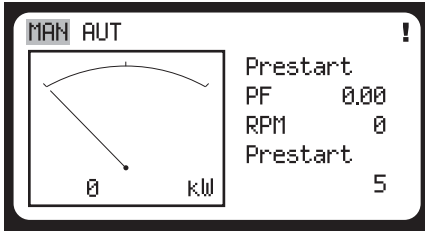

5. The Starting screen will be displayed. The engine will crank and start running.

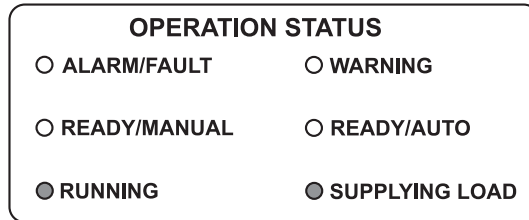
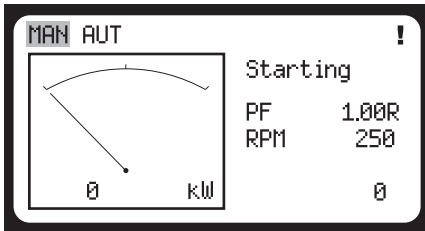

6. The Running screen will display.

Note: It may take a few seconds for the engine to run smoothly and reach its governed operating speed. The 45 second “SENSING” time delay will start to count down.

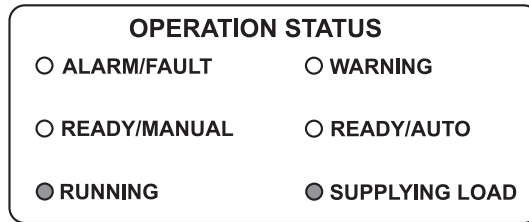
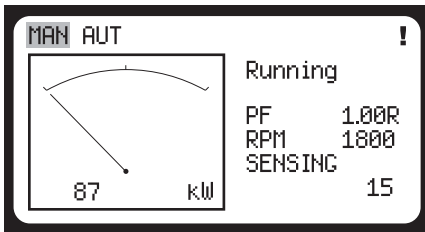

7. The LCD window will then toggle from the Running screen to the Generator Display Screen and then to the Engine Display Screen.

GENERATOR DISPLAY SCREEN

Gen freq	60.0Hz		
L1N	120V	L12	208V
L2N	120V	L23	208V
L3N	120V	L31	208V
A	226	222	223

ENGINE DISPLAY SCREEN

Oil Press	49 psi
Engine Temp	183°F
Fuel Level	83%
Ubat	13.4V

8. If the engine does not start after the first cranking attempt, the engine will pause for 15 seconds to allow the starter to cool. The LCD window will show “PAUSE”. The engine will make two more attempts to start for a total of three crank cycles.

9. Should the engine not start and run within three starting cycles, the LCD window will show “SD Start fail”. The starting sequence may be repeated after the starter has had a minimum of two minutes to cool. Press the “FAULT RESET” button to clear the controller. To start the unit, press the green “ENGINE START” button.

Note: *The engine controller may skip the preheat engine steps on some of the larger models.*

10. Once the engine starts it will immediately begin speeding up to a constant 1800 rpm. The engine may hunt or change speeds until operating speed is reached. After a few minutes of operation, the engine will be warmed up and the LCD window will show engine and generator operating parameters. Temperature will be shown as “0” until the engine temperature is approximately 100° F.
11. Check the generator for excessive noise or vibration and any coolant, oil or fuel leaks before applying any loads.
12. Check that the AC output voltage is correct. The output voltage can be fine adjusted by using the fine voltage adjustment screw (rheostat), as described on page 22.
13. Check that the frequency (Hz) is correct. With no loads connected to the generator, the frequency should read approximately 60 Hz, depending on the type of engine governing used.
14. If all wiring connections have been made correctly, switch the main circuit breaker to the “ON / I” position and then add any loads attached to the convenience outlets by switching the respective circuit breaker to the “ON / I” position. You will notice a slight change in engine sound when a load is applied to the unit.

“AUTO” (REMOTE) STARTING OF THE GENERATOR

The “AUTO” button is used when the generator is started from a location other than the control panel and by using a transfer switch. “AUTO” (remote start) is the normal setting when the generator is being used as a standby power supply. Before putting the generator in the “AUTO” mode, review the Pre-Start Check List and Manual Starting of the Generator sections beginning on page 26. Also follow all safety warnings and information on isolating the generator with a transfer switch if the unit is to be used as a standby power supply (see page 40). Then continue with the steps described below:

1. Perform a manual start of the generator at least once to verify that the engine is operating correctly.
2. If a check of the remote start circuit is desired, remove the wires from the remote start terminal block. Press the “AUTO” button, the Liquid Crystal Display (LCD) window should highlight “AUTO” in the upper left corner. Attach a jumper wire (minimum 16 gauge) across the two terminals on the remote start terminal block. This applies a ground to the Magnum Digital Controller (MDC) to close the starting circuit contacts. The engine should crank, start and run.
3. Remove the jumper wire from the remote start terminal block and the engine will stop. Reconnect any necessary wires from the remote start switch (transfer switch) to the remote start terminal block.
4. Confirm unit is in “AUTO” mode. The LCD window should have “AUT” highlighted in the upper left corner.
5. Close the main circuit breaker (set to “ON / I”).
6. Secure the generator by closing and locking all access doors.
7. The generator is now ready for remote starting.

SHUTTING DOWN THE GENERATOR

Check with personnel using power supplied by the generator and let them know that the power is going to be turned off. Make sure the power shut down will not create any hazards by accidentally turning off equipment that needs to be kept on (pumps, compressors, lights, etc.).

1. Remove all loads from the generator by opening all circuit breakers (turn to OFF / “O”).
2. Let the engine run for approximately five minutes to allow it to cool down.
3. Push the red “ENGINE STOP” button. Pressing “Engine Stop” will result in the generator going into the shut down cycle and starting a 15 second shut down timer called “Stop Value.” If the unit does not shut down within 15 seconds a “Stop Fail” alarm will be displayed on the Liquid Crystal Display (LCD) window.
4. Move the “CONTROL ON/OFF” toggle switch to the “CONTROL OFF / O” position.

MDC CONTROLLER INFORMATION DISPLAYS, FUNCTIONS AND RESET

The Magnum Digital Controller (MDC) constantly monitors vital generator and engine functions for a number of operation, alarm and fault conditions. When a fault condition occurs, the engine will shut down automatically and the Liquid Crystal Display (LCD) window will show the fault that has caused the shut down. To resume operation, the fault condition must be resolved. To reset the controller and resume operation, press the “FAULT RESET” button.

The operation of the Magnum Digital Controller (MDC) is divided into the following sections:

MAGNUM DIGITAL CONTROLLER (MDC) – GENERATOR OPERATIONAL STATUS

The Magnum Digital Controller (MDC) displays the operational status of the generator using the following codes:

No.	Engine State Machine	Description
1	AfterCool	Engine aftercooling, Cooling Pump output is closed.
2	Cooling	The unit is cooling before stop.
3	Cranking	Engine is cranking.
4	EmergMan	Emergency Manual gen-set operation.
5	Init	Autotest during controller power on.
6	Loaded	The unit is running at nominal speed and GCB OPEN/CLOSE is closed.
7	Not Ready	The unit is not ready to start.
8	Pause	Pause between start attempts.
9	Prestart	Prestart sequence in process, Prestart output is closed.
10	Ready	The unit is ready to run.
11	Running	The unit is running at nominal speed.
12	Shutdown	Shut-down alarm is activated.
13	Starting	Starting speed is reached and the <i>Idle timer</i> is running.
14	Stop	Stop
No.	Electrical State Machine	Description
1	StabilTO	Stabilization Timeout

MAGNUM DIGITAL CONTROLLER (MDC) - ALARM MANAGEMENT

The Magnum Digital Controller (MDC) is capable of displaying the following alarms:

No.	Type	Description
1	Sensor fail (FLS)	Sensor fail is detected when measured value is 6% out of the selected characteristic. Sensor fail indicated by ##### symbol instead measured value.
2	Warning (WRN)	When warning comes up, see list of possible alarms.
3	Shut down (SD)	When the shut-down alarm comes up the Magnum Digital Controller opens outputs GCB CLOSE/OPEN, FUEL, SOLENOID, STARTER AND PRESTART to stop the engine immediately.

MAGNUM DIGITAL CONTROLLER (MDC)- LIST OF POSSIBLE ALARMS/DESCRIPTIONS

Shut down and warning fault conditions and the displayed message are described in the following table:

No.	Events Specification	Protection Type	Information on Binary Output Available	Description
1	AnInIOM Sd	SD	YES	Shutdown alarm configurable on the input of IG-IOM/IGS-PTM.
2	AnInIOM Wrn	WRN	YES	Warning alarm configurable on the input of IG-IOM/IGS-PTM.
3	Battery Flat	SD	YES	If the controller switches off during starting sequence due to bad battery condition it doesn't try to start again and activates this protection.
4	Binary Input	Configurable	YES	Configurable Warning/Shutdown alarms on the inputs of IL-NT.
5	ChrgAlternFail	WRN	YES	Failure of the alternator for charging the battery.
6	EmergencyStop	SD	NO	If the input <i>Emergency stop</i> is opened shutdown is immediately activated.
7	Engine Temp Sd	SD	NO	Water temperature is greater than <i>Sd Water temp</i> setpoint.
8	Engine Temp Wrn	WRN	YES	Water temperature is greater than <i>Wrn Water temp</i> setpoint.
9	Fgen <, >	SD	YES	The generator frequency is out of limits given by <i>Gen >f</i> and <i>Gen <f</i> setpoints.
10	Fuel Level Sd	SD	YES	Fuel level is less than <i>Sd Fuel Level</i> setpoint.
11	Fuel Level Wrn	WRN	YES	Fuel level is less than <i>Wrn Fuel Level</i> setpoint.
12	GCB fail	SD	NO	Failure of the generator circuit breaker.
13	Igen unbl	SD	NO	The generator current is unbalanced.
14	Low BackupBatt	WRN	NO	RTC backup battery is flat.
15	Oil Press Sd	SD	NO	Oil pressure is less than <i>Sd Oil press</i> setpoint.
16	Oil Press Wrn	WRN	YES	Oil pressure is less than <i>Wrn Oil press</i> setpoint.
17	Overload	SD	YES	The load is greater than the value given by <i>Overload</i> setpoint.
18	Overspeed	SD	YES	The protection comes active if the speed is greater than <i>Overspeed</i> setpoint.
19	ParamFail	NONE	NO	Wrong checksum of parameters. Happens typically after downloading new firmware or changing of the parameter. The controller stays in INIT mode. Check all parameters write at least one new parameter.
20	PickupFault	SD	NO	Failure of the magnetic pick-up sensor for speed measurement.
21	Sd IOM fail	SD	NO	Shutdown alarm in case of lost connection to IG-IOM/IGS-PTM module.
22	SprinklActive	WRN	NO	The protection is active if the output <i>Sprinkler</i> is closed.
23	Start failed	SD	YES	Gen-set start failed
24	Stop fail	SD	YES	Gen-set stop failed.
25	Ubat	WRN	YES	Battery voltage is out of limits given by <i>Batt overvolt</i> and <i>Batt undervolt</i> setpoints.
26	Underspeed	SD	YES	During starting of the engine when the RPM reaches the value of <i>Starting RPM</i> setpoint the starter is switched off and the speed of the engine can drop under <i>Start RPM</i> again. Then the Underspeed protection becomes active. Protection evaluation starts 5 sec
27	Vgen <, >	SD	YES	The generator voltage is out of limits given by <i>Gen <V</i> and <i>Gen >V</i> setpoints.

28	Vgen unbal	SD	NO	The generator voltage is unbalanced more than the value of <i>Volt unbal</i> setpoint.
29	Wrn ECU Alarm	WRN	NO	ECU alarm list is not empty.
30	Wrn RA15 fail	WRN	NO	Warning alarm in case of lost connection to IGL-RA15 module.
31	WrnServiceTime	WRN	NO	The period for servicing is set by the <i>NextServTime</i> setpoint. The protection comes active if the running hours of the engine reach this value.

MMG ENGINE CONTROLLER

The engine speed (RPM) of the MMG 35FH and MMG 55FH units is regulated with a Woodward Controller. The engine speed (RPM) of the MMG 25FHI and MMG 45FHK units is regulated with a Governors America Corps. (GAC) controller. The Magnum Digital Controller (MDC) constantly monitors vital engine functions for a number of operation, alarm, and fault conditions. When an operation, alarm or fault condition occurs, the LCD display will alert the operator either visually or audibly. Press the “▲” Scroll-Up button (on the diagnostic keypad) to view the “Alarm List.” This will allow you to view a description of the fault, (See Figure 1).

ADJUSTING THE DISPLAY BACK LIGHTING

The brightness on the Liquid Crystal Display (LCD) window may be adjusted by the operator whenever the Magnum Digital Controller (MDC) is powered up.

Note: Anytime an “*” is displayed on the LCD window, the text or set point cannot be changed without the use of a password. Contact Magnum Products Technical Support for assistance.

1. Press and hold “Enter,” then press “▲” or “▼” on the Diagnostics keypad to increase or decrease the brightness as needed.
2. Release the “Enter” button when the desired brightness is attained.

MDC CONTROLLER (MDC) – HISTORY

The Magnum Digital Controller (MDC) stores a record of each important event into the history file of the controller. The history file seats 118 records. When the history file is full, the oldest records are removed.

No.	Record Structure Abbreviation	Historical value
1	AIM1	IG-IOM, IGS-PTM Analog input 1 value (when configured IG-IOM, IGS-PTM)
2	AIM2	IG-IOM, IGS-PTM Analog input 2 value (when configured IG-IOM, IGS-PTM)
3	AIM3	IG-IOM, IGS-PTM Analog input 3 value (when configured IG-IOM, IGS-PTM)
4	AIM4	IG-IOM, IGS-PTM Analog input 4 value (when configured IG-IOM, IGS-PTM)
5	BIM	IG-IOM, IGS-PTM Binary inputs (when configured IG-IOM, IGS-PTM)
6	BIN	Binary inputs IL-NT
7	BOM	IG-IOM, IGS-PTM Binary outputs (when configured IG-IOM, IGS-PTM)
8	BOU	Binary inputs IL-NT
9	Date	Date of historical event in format DD/MM/YY
10	EngT	IL-NT Analog input 2 value (default Water temperature)
11	FC	ECU alarm FailureCode
12	FLvl	IL-NT Analog input 3 value (default Fuel level)
13	FMI	ECUalarm Failure Mode Identifier
14	Gfrg	Generator frequency
15	Ig1	Generator current L1
16	Ig2	Generator current L2
17	Ig3	Generator current L3
18	LChr	Character of the load
19	Num	Number of historical event
20	OilP	IL-NT Analog input 1 value (default Oil pressure)
21	PF	Generator PF
22	Pwr	Generator active power
23	Reason	Event specification
24	RPM	Engine Speed
25	Time	Time of historical event in format HH:MM:SS
26	Ubat	Battery voltage
27	Vg1	Generator voltage L1
28	Vg2	Generator voltage L2
29	Vg3	Generator voltage L3

RESETTING OF THE “TIME TO SERVICE” REMINDER

The Magnum Digital Controller (MDC) will display the message “WrnServiceTime” when the unit is due for maintenance or service. The maintenance or service interval is set at 250 hours of engine running time. Once the unit has been serviced, the “ServiceTime” reminder needs to be reset to the 250 hour interval. The following procedure demonstrates how to reset the running hours to 250:

1. With the unit shut down, power up the controller with the “Control On/Off” Toggle Switch. The initialization screen will be displayed. The controller will toggle automatically to the “Ready” Display screen.
2. Press the “▲” button. The “Alarm List” display screen will appear. The next screen will display lines of text; starting with the word “Password”, then “Basic Settings”, “Engine Params”, “Engine Protect” etc. The top line has a cursor (>) before the word “Password”.
3. Press the “▼” button to move the cursor (>) down to the “Engine Protect” line of text.
4. Press Enter. “NextServTime” will appear at the top left of the display screen. The current service time hour setting (250) will be one line below it on the right side.
5. Press Enter. The current run time in hours will now appear on the left side of the display screen, directly under “NextServTime.”
6. Press the “▲” button and reset the current run time hour setting to 250. If you pass the 250 time interval use the “▼” button to get back to the 250 time interval.
7. Press “Enter” to save the current run time hour setting.
8. Move the “CONTROL ON / I” toggle switch to the “CONTROL OFF / O” position.

TROUBLESHOOTING AUTOMATIC SHUT DOWN CONDITIONS

▲ WARNING

Allow engine to cool before performing any troubleshooting procedures. Contacting the engine when it is hot will cause severe personal injury.

LOW FUEL LEVEL SHUT DOWN

1. Check the fuel level on the Liquid Crystal Display (LCD) window.
2. Check for leaks in the fuel tank. The fuel tank will not run dry under normal circumstances. The engine controller will shut the engine down when there is five percent of fuel remaining in the tank. This is done to keep the fuel lines from running dry.
3. If the fuel level is good and no leaks are found, check the fuel level sender and the connecting wiring for damage. To check for continuity between the sender and the engine controller, remove the appropriate bolts from the control panel to access the inside of the control box. Consult the appropriate DC wiring diagram for the proper path between the engine controller and the fuel level sender.

LOW OIL PRESSURE SHUT DOWN

1. Check the level of the engine oil with the dipstick. The engine controller will shut the engine down when the oil pressure is less than 20 psi. Add oil if required.
2. Visually inspect the engine for oil leaks.
3. If the oil level is good, restart the unit and verify the loss of oil pressure. Shut the engine down immediately if the oil pressure value does not read five (5) psi within five (5) seconds.
4. Check the oil pressure sender on the engine block and the connecting wiring for damage. To check for continuity between the sender and the engine controller, remove the appropriate bolts from the control panel to access the inside of the control box. Consult the appropriate DC wiring diagram for the proper path between the engine controller and the pressure sender.
5. If the oil level, pressure sender and wiring are good, the oil loss may be caused by engine failure. Consult the engine OPERATION AND MAINTENANCE MANUAL for additional information on excessive oil consumption.

LOW COOLANT LEVEL SHUT DOWN

1. Allow the engine to cool!

2. Check the coolant level in the radiator. To access the radiator cap, you must open the front hood. Add coolant until it is 3/4" below the filler neck. Secure the radiator cap back into its original position.
3. Inspect coolant hoses, engine block and water pump for visible leaks.

HIGH COOLANT TEMPERATURE SHUT DOWN

1. Check the coolant level in the overflow jug.
2. Restart the engine and read the coolant temperature to verify High Coolant Temperature Shut Down. The engine will stop if the coolant temperature is 230°F or more.
3. Allow the engine to cool. Add coolant to the overflow jug if it is low and then check the level of coolant in the radiator. To access the radiator cap, you must open the front hood. Add coolant until it is 3/4" below the filler neck. Secure the radiator cap back into its original position.
4. Check the radiator shroud and ducting for blockage and remove any foreign matter.
5. Check the tension of the serpentine drive belt for the water pump.
6. Check the coolant temperature sender on the engine block and the connecting wiring for damage. To check for continuity between the sender and the engine controller, remove the appropriate bolts from the control panel to access the inside of the control box. Consult the appropriate DC wiring diagram for the proper path between the engine controller and the temperature sender.
7. If the sender and wiring are good and no other problems are found, remove the load on the generator and restart the engine. Observe the coolant temperature and shut the engine down immediately if it starts to overheat. Consult the engine OPERATION AND MAINTENANCE MANUAL for additional information on engine overheating.

OVERCRANK SHUT DOWN

1. Check the fuel level in tank.
2. Check for proper operation of the fuel pump.
3. Check air filter for blockage.
4. If the engine will not start, consult the engine OPERATION AND MAINTENANCE MANUAL for additional information on troubleshooting starting problems.

OVERSPEED OR UNDERSPEED SHUT DOWN

1. Disconnect all loads and restart the generator. Read the frequency (Hz) on the LCD display. With no loads on the generator, the frequency should read 60.0 Hz.
2. If the frequency is above or below 60.0 Hz, the engine speed will have to be adjusted. See the engine manual for throttle adjustments on mechanical governed units and see the electronic governor manual for electronically controlled units.

GENERATOR OUTPUT CONNECTION LUGS

The generator is equipped with connection lugs behind the lug door next to the customer convenience outlets. The lugs provide connection points for attachment of external loads to the generator. A large decal on the inside of the connection lug door details the proper connections for selected voltages.

▲ WARNING

It is **RECOMMENDED** that only a trained and licensed electrician perform any wiring and related connections to the generator. Installation should be in compliance with the **NATIONAL ELECTRIC CODE (NEC)** as well as any local or state guidelines as required by law. Failure to follow proper installation requirements may result in equipment or property damage, personal injury or death.

▲ WARNING

Before any connections are made to the generator, make sure that the main circuit breaker and the engine start switch are in the OFF "O" position and that the negative (-) battery cable is disconnected. Potentially lethal voltages may be present at the generator connection lugs.

▲ DANGER

IMPROPER OR INCORRECT CONNECTIONS TO A BUILDINGS ELECTRICAL SYSTEM CAN CAUSE POTENTIALLY LETHAL VOLTAGE TO BACKFEED ONTO UTILITY LINES. THIS MAY RESULT IN INJURY OR ELECTROCUTION TO UTILITY WORKERS NEARBY. MAKE SURE THE GENERATOR IS SUPPLYING POWER TO AN ISOLATED OBJECT OR BUILDING THAT IS NOT CONNECTED TO ANY UTILITY LINES.

Use a hex-wrench to tighten the cable connections. The lug door is equipped with safety interlock switches that will trip the main circuit breaker and disable the voltage regulator, dropping the operator output to residual voltage, if the door is opened while the unit is operating.

▲ WARNING

Never attempt to disable or modify the connection lug door safety switches. Equipment damage, personal injury or death may result.

A ground connection is located next to the connection lugs. The unit **MUST** be connected to a good earthen ground for proper operating safety. The ground connection **SHOULD BE IN COMPLIANCE WITH THE NATIONAL ELECTRIC CODE (NEC) AS WELL AS ANY STATE OR LOCAL GUIDELINES OR CODES.**

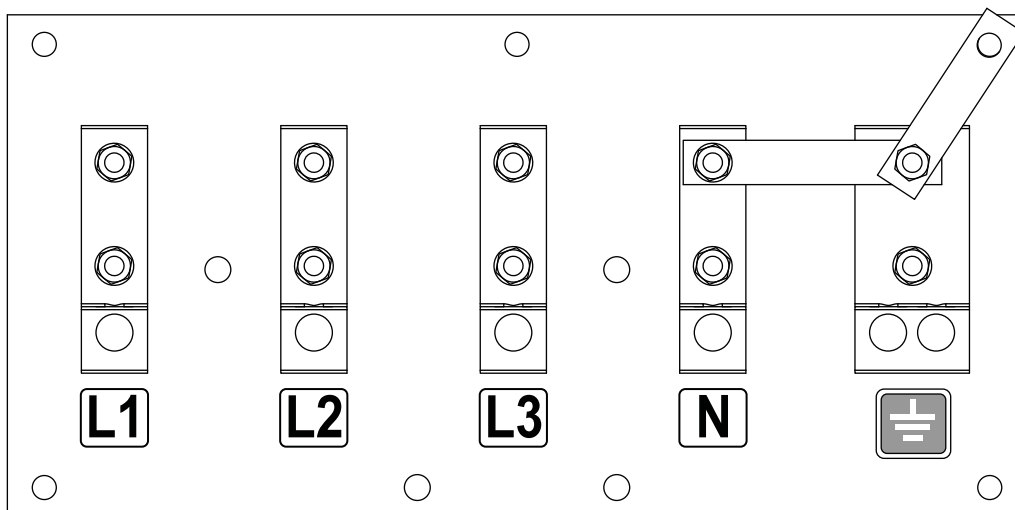

GENERATOR CAM LOCK CONNECTIONS (OPTIONAL)

The generator may be equipped with cam lock connections located behind the lug door next to the customer convenience outlets. These receptacles provide connection points for attachment of external loads to the generator. A large decal on the inside of the connection lug door details the proper connections for selected voltages.

▲ WARNING

It is **RECOMMENDED** that only a trained and licensed electrician perform any wiring and related connections to the generator. Installation should be in compliance with the **NATIONAL ELECTRIC CODE (NEC)** as well as any local or state guidelines as required by law. Failure to follow proper installation requirements may result in equipment or property damage, personal injury or death.

▲ WARNING

Before any connections are made to the generator, make sure that the main circuit breaker and the engine start switch are in the OFF "O" position and that the negative (-) battery cable is disconnected. Potentially lethal voltages may be present at the generator cam lock receptacles.

▲ DANGER

IMPROPER OR INCORRECT CONNECTIONS TO A BUILDINGS ELECTRICAL SYSTEM CAN CAUSE POTENTIALLY LETHAL VOLTAGE TO BACKFEED ONTO UTILITY LINES. THIS MAY RESULT IN INJURY OR ELECTROCUTION TO UTILITY WORKERS NEARBY. MAKE SURE THE GENERATOR IS SUPPLYING POWER TO AN ISOLATED OBJECT OR BUILDING THAT IS NOT CONNECTED TO ANY UTILITY LINES.

Connections should be made by plugging power cables equipped with series 16 taper nose 400A, 600V cam lock plugs into the cam lock receptacles. Secure the connection by rotating the plug a 1/4 turn to the right. The connection lug door is equipped with safety interlock switches that will trip the main circuit breaker and disable the voltage regulator, dropping the operator output to residual voltage, if the door is opened while the unit is operating.

▲ WARNING

Never attempt to disable or modify the connection lug door safety switches. Equipment damage, personal injury or death may result.

A ground connection is located on the far right of the cam lock panel. The unit **MUST** be connected to a good earthen ground for proper operating safety. The ground connection **SHOULD BE IN COMPLIANCE WITH THE NATIONAL ELECTRIC CODE (NEC) AS WELL AS ANY STATE OR LOCAL GUIDELINES OR CODES.**

L1	Black
L2	Red
L3	Blue
N (Neutral)	White
G (Ground)	Green

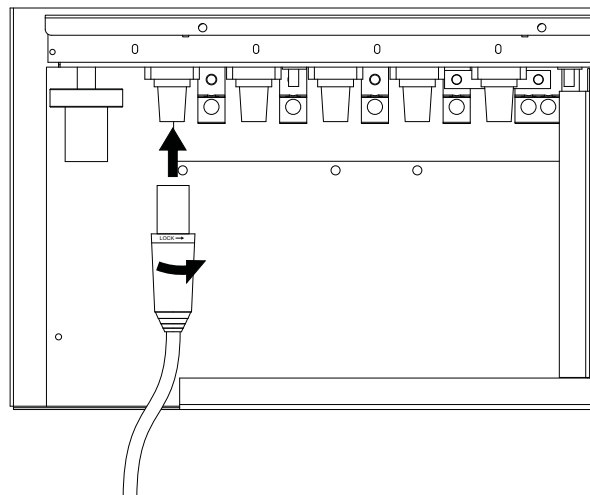

VOLTAGE SELECTOR SWITCH

The voltage selector switch is located under the control panel, next to the output connection lugs. The selector switch is a three position switch that mechanically changes the connections between the generator output leads and the connection lugs or optional cam lock connectors. Voltage ranges are selected by rotating the handle on the switch to the desired voltage.

NOTICE

NEVER attempt to change the voltage selector switch while the engine is running! This will cause severe arcing and damage to the switch and generator windings.

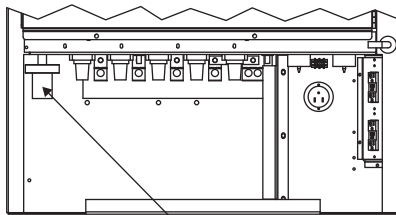

VOLTAGE
SELECTOR
SWITCH

480/277V 3-PHASE

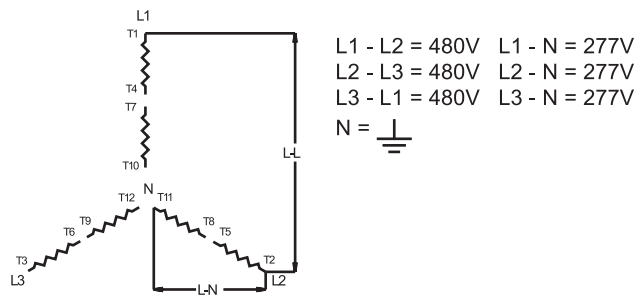

208/120V 3-PHASE

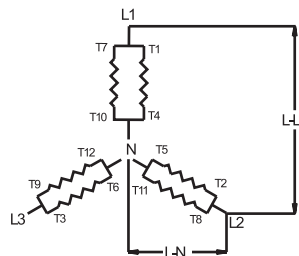

$L1 - L2 = 208V$ $L1 - N = 120V$
 $L2 - L3 = 208V$ $L2 - N = 120V$
 $L3 - L1 = 208V$ $L3 - N = 120V$
 $N = \text{ground symbol}$

240/120V 1-PHASE

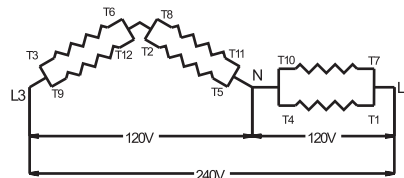

$L1 - L3 = 240V$ $L2 - N = \text{-----}$
 $L1 - N = 120V$ $L3 - N = 120V$

The connection lug door is equipped with safety interlock switches that will trip the main circuit breaker and disable the voltage regulator, dropping the operator output to residual voltage, if the door is opened while the unit is operating.

⚠ WARNING

Never attempt to disable or modify the lug door safety switches. Equipment damage, personal injury or death may result.

Note: When the voltage selector switch is in position for 480/277V 3 ϕ , voltage at the two GFCI duplex convenience outlets is 139 Volts and the voltage at the two twist-lock outlets is 240/139 Volts. When the voltage selector switch is in position for 208/120V 3 ϕ , voltage at the two twist-lock outlets and the two GFCI duplex convenience outlets is 208/120 Volts.

4-POSITION VOLTAGE SELECTOR SWITCH (OPTIONAL)

The voltage selector switch is located under the control panel, next to the connection lugs. This optional selector switch is a four position switch that mechanically changes the connection between the generator output leads and the connection lugs or optional cam lock connectors. Voltage ranges are selected by rotating the handle on the switch to the desired voltage.

NOTICE

NEVER attempt to change the voltage selector switch while the engine is running! This will cause severe arcing and damage to the switch and generator windings.

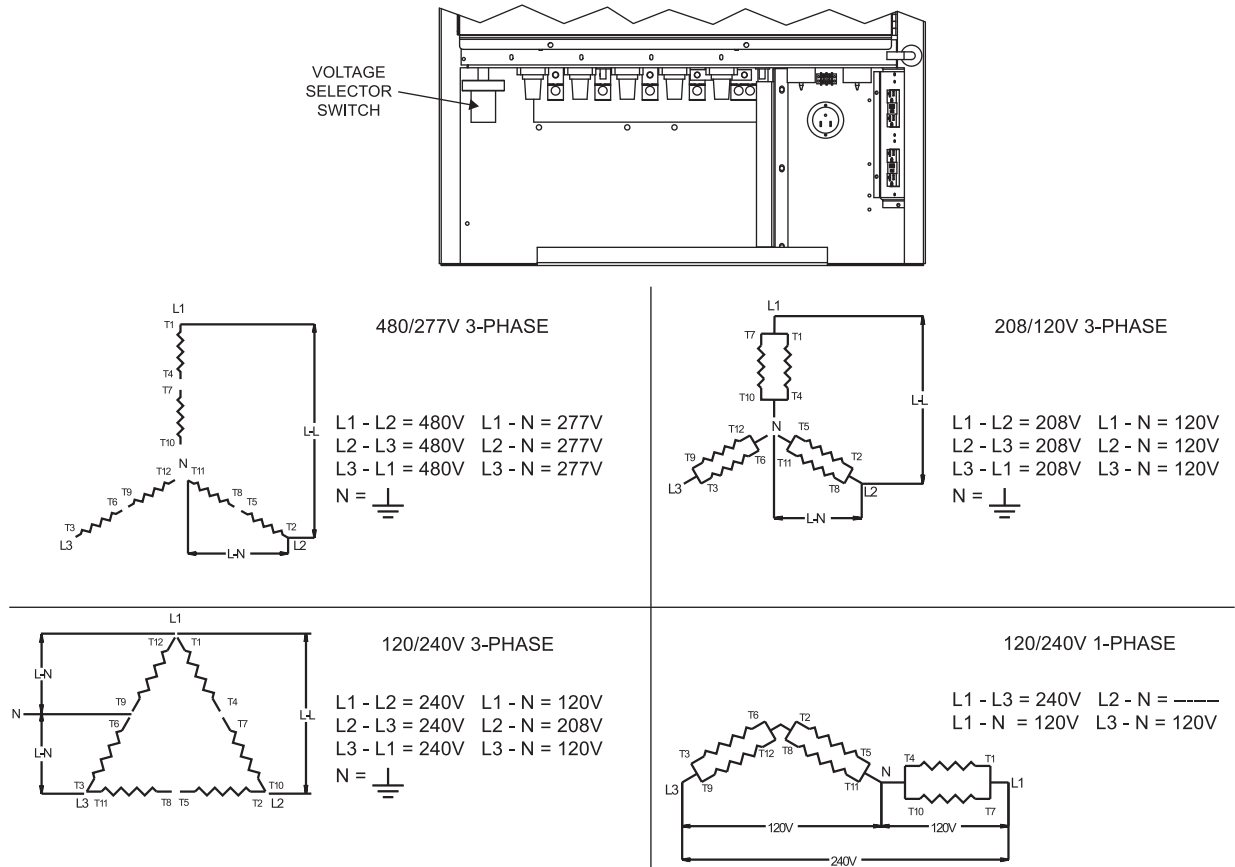

The connection lug door is equipped with safety interlock switches that will trip the main circuit breaker and disable the voltage regulator, dropping the operator output to residual voltage, if the door is opened while the unit is operating.

⚠ WARNING

Never attempt to disable or modify the lug door safety switches. Equipment damage, personal injury or death may result.

Note: (The following applies to units without a convenience outlet buck transformer.) When the voltage selector switch is in position for 480/277V 3Ø, voltage at the two GFCI duplex convenience outlets is 139 Volts, and the voltage at the two twist-lock convenience outlets is 240/139 Volts. When the voltage selector switch is in position for 208/120V 3Ø, voltage at the two GFCI duplex convenience outlets is 120 Volts, and the voltage at the two twist-lock convenience outlets is 208/120 Volts. When the voltage selector switch is in position for 120/240 3Ø (DELTA), voltage at the two GFCI duplex convenience outlets is 120 Volts, and the two **TWIST-LOCK OUTLETS SHOULD NOT BE USED**. When the voltage selector switch is in position for 120/240V 1Ø, voltage at the two GFCI duplex convenience outlets is 120 Volts, and the voltage at the two twist-lock outlets is 120/240 Volts.

EMERGENCY STOP SWITCH

The generator is equipped with one emergency stop switch, located on the rear corner of the unit next to the control panel door. The switch is clearly labeled with “**EMERGENCY STOP**” and it is red in color. The switch can be accessed and activated with all doors closed and locked.

Activate the emergency stop switch by pushing the red button in until it locks down. This will trip the main circuit breaker which will open the contact disconnecting the load to the connection lugs. This will also open the fuel circuit, shutting down the engine. The “EMERGENCY STOP FAULT” will be displayed on the LCD.

The switch will remain closed until it is pulled out.

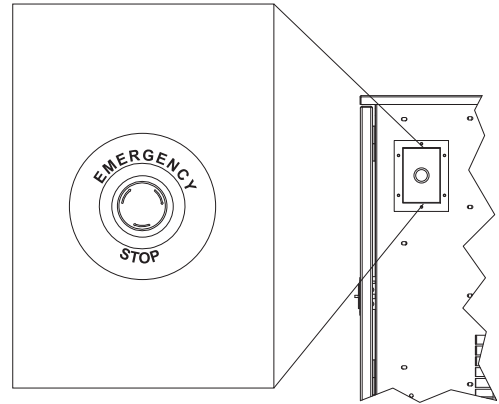

NOTICE

Use the emergency stop switch only when the generator must be shut down immediately. For any other shut down, follow the detailed procedure on page 28.

MAIN CIRCUIT BREAKER

The main circuit breaker is located on the main control panel. When the breaker is in the OFF “O” position, power is interrupted between the customer connection lugs, optional cam lock connectors and the generator. Once the connections have been made to the connection lugs and the generator has been started and allowed to reach normal operating temperature, the breaker may be switched to the ON “I” position.

The main circuit breaker will be tripped, disconnecting power to the connection lugs, if any of the following items occur while the unit is running:

1. Overload of the generator circuits to the connection lugs and optional cam lock connectors.
2. The connection lug door is opened.
3. If the emergency stop switch is activated.

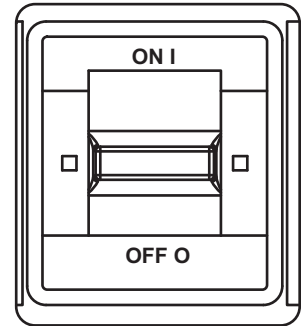

Make sure that any problems that cause the main circuit breaker to trip are corrected before returning the switch to the ON “I” position.

⚠ CAUTION

The main circuit breaker interrupts power to the customer connection lugs and optional cam lock connectors only! The customer convenience outlets have power even if the main circuit breaker is in the OFF “O” position. To disconnect power to the convenience outlets, use the individual circuit breakers located near each outlet.

VOLTAGE REGULATION

The electronic voltage regulator controls the output of the generator by regulating the current into the exciter field. The regulator has three screwdriver adjustable potentiometers that may be adjusted for voltage, stability and voltage roll-off (U/F). The voltage regulator on your unit is adjusted before shipment from the factory. Contact Magnum Products LLC for additional information before attempting to adjust the voltage regulator.

CUSTOMER CONVENIENCE OUTLETS

The generator is equipped with four convenience outlets. The large outlets are 240/120 VAC twist-lock receptacles rated at 50A each. The smaller outlets are 120 VAC duplex receptacles rated at 20A each with ground fault interrupt (GFCI) protection. These receptacles are not routed through the main circuit breaker. Each receptacle has its own circuit breaker, located directly above the receptacle panel, with the breaker sized to the maximum rating of the corresponding outlet.

NOTICE

Power to the outlets is available any time the generator is running, even if the main circuit breaker is OFF ("O"). Make sure that any equipment connected to the convenience outlets is turned off before turning the breakers on. Make sure that the voltage selector switch is in the proper position and that the output voltage is correct for the equipment that is connected to the outlets. Improper voltage may cause equipment damage or malfunction.

Note: When the voltage selector switch is in position for 480/277V 3Ø, voltage at the two GFCI duplex convenience outlets is 139 Volts, and the voltage at the two twist-lock outlets is 240/139 Volts. When the voltage selector switch is in position for 208/120V 3Ø, voltage at the two twist-lock outlets and the two GFCI duplex convenience outlets is 208/120 Volts.

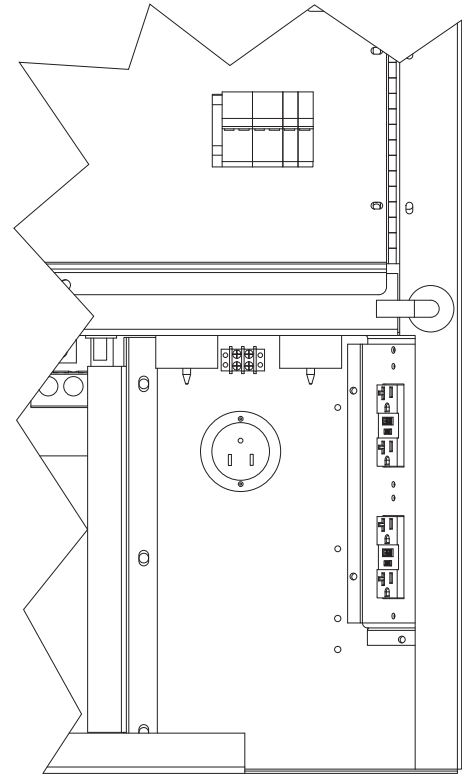

DERATING FOR ALTITUDE

All generator sets are subject to derating for altitude and temperature; this will reduce the available power for operation of tools and accessories connected to the auxiliary outlets. Typical reductions in performance are 2-4% for every 1000 ft. (305 meters) of elevation and 1% per 10° F (3-5° C) increase in ambient air temperature over 72° F (22.2° C).

REMOTE START TERMINAL BLOCK.

The remote start terminal block is located between the two 240/120V VAC twist-lock convenience outlets. It provides a connection for installation of a remote start switch which will allow the generator to be started by a remote dry-contact closure switch.

Before pressing the AUTO button, verify the contacts on any remote switch linked to the generator are OPEN. If the contacts on a remote switch are closed, the generator will crank and start when AUTO is selected. Attach the switch leads to the two unused terminals on the generator's remote start block. For additional information on starting the generator, see page 26.

When the generator is used as a standby power supply, it must be equipped with a transfer switch which isolates it from the utility's distribution system. A transfer switch is designed to transfer electrical loads from the normal power source (utility) to the emergency power source (generator) when normal voltage falls below a prescribed level. The transfer switch automatically returns the load back to the normal source when power is restored back to operating levels.

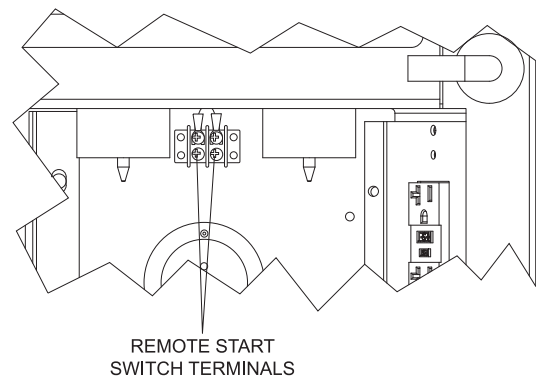

⚠ DANGER

FAILURE TO ISOLATE THE GENERATOR FROM THE NORMAL POWER UTILITY CAN CAUSE POTENTIALLY LETHAL VOLTAGE TO BACKFEED INTO THE UTILITY LINES. THIS MAY RESULT IN INJURY OR ELECTROCUTION OF UTILITY WORKERS NEARBY. MAKE SURE THAT THE GENERATOR IS ISOLATED BY A TRANSFER SWITCH FROM ANY LOCAL UTILITY LINES. THIS ALSO APPLIES IF THE GENERATOR IS BEING USED AS A BACK UP TO SOME OTHER TYPE OF POWER SUPPLY.

Installation of a transfer switch or other type of remote starting device is the responsibility of the generator user. Installation of such devices must be performed by following all directions supplied by the manufacturer of the switch. If attaching generator to a power supply normally serviced by a utility company, notify the utility company and check local and state regulations. Familiarize yourself with all instructions and warning labels supplied with the switch.

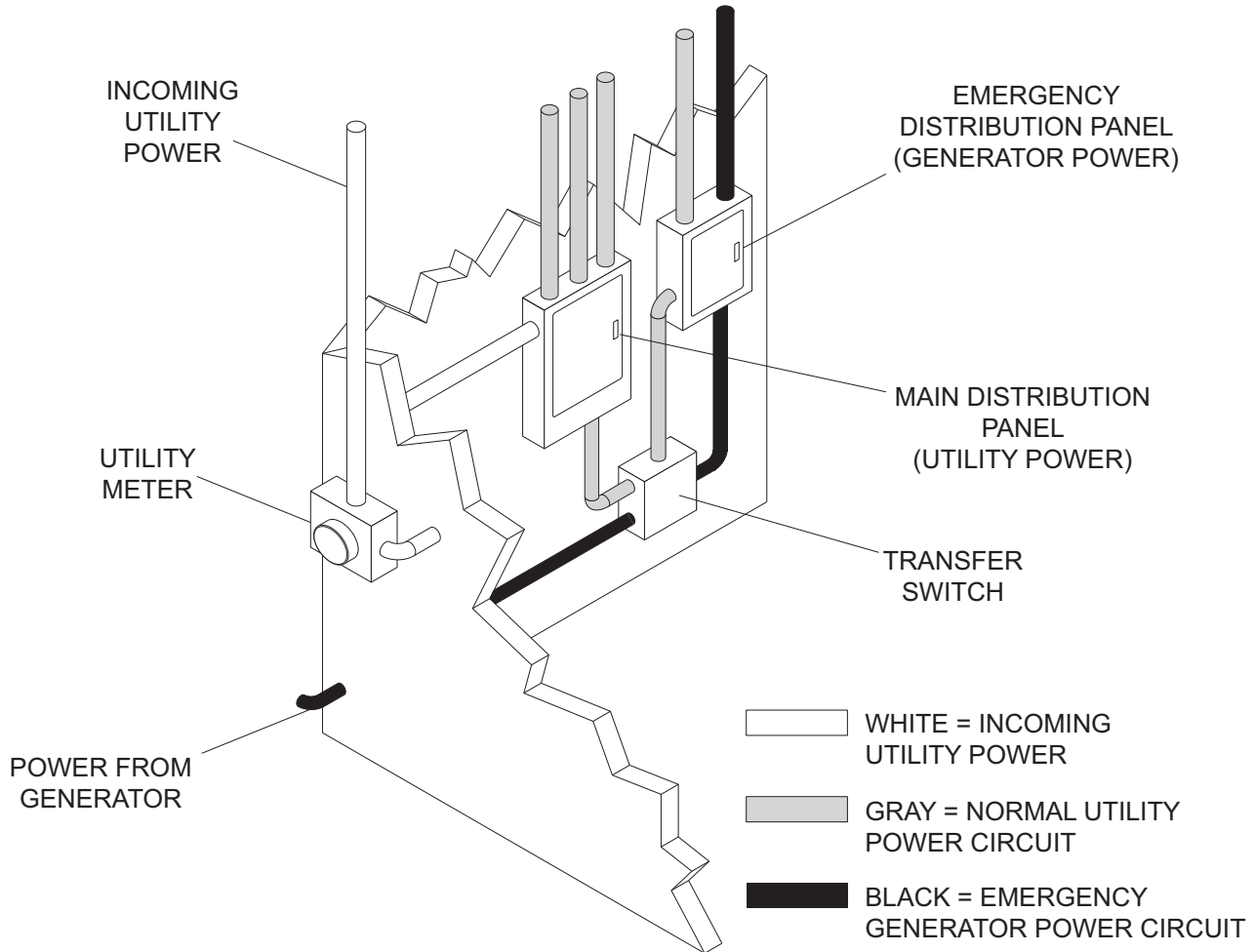

⚠ WARNING

ONLY a licensed electrician perform any wiring and any related connections to the generator. Installation should be in compliance of the National Electric Code as well as any state or local codes or regulations. Failure to follow these procedures could result in property damage, personal injury or death. Before any connections are attempted, make sure the main circuit breaker and the engine start switch are in the OFF "O" position and that the negative (-) battery cable has been disconnected from the engine starting battery.

NOTICE

When using the generator as a standby or substitute power supply, make sure the output voltage and phase rotation of the generator match those of the local power utility. Improper voltage or phase rotation may cause equipment damage or malfunction.

ENGINE BREAK-IN REQUIREMENTS

Note: During the first 20 hours of operation, avoid long periods of no load or sustained maximum load operation. If the generator is to run for longer than five minutes without a load, shut the generator down.

The engine is supplied with engine break-in oil from the factory. Extra care during the first 100 hours of engine operation will result in better performance and longer engine life. **DO NOT** exceed 100 hours of operation with the break-in oil. Operate the engine at heavy loads (60-90% of maximum) as much as possible. If the engine has spent significant time at idle, constant speed(s) and/or light load or if makeup oil is required, a longer break in period may be needed. Consult the engine OPERATION AND MAINTENANCE MANUAL for a full description of necessary procedures on the addition of oil and extension of the break-in period. Use the schedule table on page 43 as a guide for regular maintenance intervals.

DAILY WALK AROUND INSPECTION

Look for conditions that could hinder performance or safety, such as (but not limited to) oil/coolant/fuel leakage, blocked vents, loose/missing hardware and electrical connections.

Visually inspect the fan belt for cracks, fraying, stretching and that the belt is properly seated in pulley grooves. Replace the belt according to the manufacturer's recommendations.

▲ CAUTION

Failure to perform a daily inspection may result in serious damage to the prime mover.

Note: At the 500 hour/12 month service interval, it is recommended that the belt be removed and checked for wear. While the belt is removed, inspect pulleys and bearings. Rotate and feel for hard turning or unusual sounds. If pulleys or bearings need replacement contact engine manufacturer.

JOHN DEERE ENGINES ONLY

John Deere engines use two types of belt tensioners: manual and automatic. Adjust the belt using the manual tensioner according to the manufacturer's specifications. The automatic tensioner cannot be adjusted or repaired and is designed to maintain proper tension over the belt's life. Units with the automatic belt tensioner must be inspected according to the manufacturer's specifications.

ENGINE AND GENERATOR MAINTENANCE

Poorly maintained equipment can become a safety hazard! In order for the equipment to operate safely and properly over a long period of time, periodic maintenance and occasional repairs are necessary. NEVER perform even routine service (oil/filter changes, cleaning, etc.) unless all electrical components are shut off. When servicing this equipment always follow the instructions listed below.

- Before servicing the machine, make sure the engine start switch is turned to the OFF "O" position.
- The circuit breakers are open (OFF, "O").
- The emergency stop switch is activated (pushed in).
- The negative (-) terminal on the battery is disconnected.
- Attach a "DO NOT START" sign to the control panel. This will notify everyone that the unit is being serviced and will reduce the chance of someone inadvertently trying to start the unit.
- If the unit is connected to a remote start or transfer switch, make sure the remote switch is also off and tagged.
- Never wash the unit with a high pressure hose or with any kind of power washer.
- Never wash the engine block or fuel tank with a power washer or steam cleaner. Water may enter the cabinet and collect in the generator windings or other electrical parts causing damage.
- If the unit is stored outside, check for water inside the cabinet and generator before each use. If wet, dry the unit thoroughly before starting.

DAILY MAINTENANCE CHECKS

Check the engine oil level daily before starting engine. DO NOT start the generator if the oil level is below the ADD mark on the dipstick. The normal operating level for the engine oil is anywhere in the crosshatch pattern between the FULL and ADD markings. Add oil to the engine only if the level is below the ADD mark on the bottom of the crosshatch pattern. DO NOT OVERFILL the crankcase. Consult the engine OPERATION AND MAINTENANCE MANUAL for the proper grade of oil, including special operating conditions such as a change in season or climate.

Check the coolant level daily. The coolant is checked by visually inspecting the level in the coolant overflow jug, located near the radiator. The normal operating level is anywhere between the FULL and ADD markings on the overflow jug, with the optimum level noted as "NORMAL RANGE". Coolant may be added directly to the overflow jug WHEN THE ENGINE IS STOPPED AND COMPLETELY COOL. Consult the engine OPERATION AND MAINTENANCE MANUAL for coolant recommendations and proper mixture.

Check the condition of the air filter by viewing the level of vacuum draw on the filter minder gauge. Replace the air filter when the yellow center bar reaches the red section on the gauge (20 in. H₂O).

ITEM	DAILY	50 HRS.	250 HRS.	500 HRS.	1000 HRS.	ANNUALLY
Check engine oil level	◆					
Check air cleaner and filter minder gauge*	◆					
Check engine coolant level	◆					
Visual walk around inspection	◆					
Check fuel filter		◆				
Service battery			◆			
Inspect radiator for blockage, clean as necessary			◆			
Change engine oil and replace filter**			◆			
Replace fuel filter element			◆			
Inspect oil vapor recirculation filter (if equipped)			◆			
Check air intake hoses, connections and system				◆		
Check automatic belt tensioner and belt wear				◆		
Check cooling system				◆		
Perform coolant solution analysis				◆		
Replace oil vapor recirculation filter (if equipped)					◆	
Pressure test cooling system					◆	
Flush cooling system***					◆	
Check and adjust engine valve clearance					◆	
Check generator drive plate torque (see procedure on page 45)****						◆

* Replace primary air cleaner when restriction indicator shows a vacuum of 25 in. H₂O.

** Change the oil and oil filter after the first 100 hours, then every 250 hours.

*** If engine manufacturer's recommended coolant is used, the flushing interval may be extended. See engine OPERATION AND MAINTENANCE MANUAL.

**** Check the torque of the generator drive plate bolts after the first 250 hours of operation, then annually.

LIFTING THE GENERATOR

A large central lifting eye is located on the top of the generator. The eye is connected to a central lifting frame inside the unit. Attach a sling or hook directly to the lifting eye only if the devices are in good condition and the equipment being used to raise the unit has sufficient capacity. Approximate weights can be found on pages 8 - 13. Always remain aware of others around you when moving or lifting the generator. Keep the cabinet doors closed and locked.

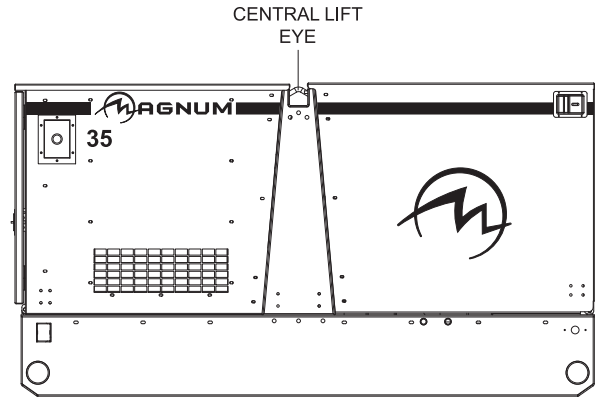

TOWING THE TRAILER

1. Use the jack to raise or lower the trailer onto the hitch of the towing vehicle. Lock the hitch coupling and attach the safety chains or cables to the vehicle. Release the jack locking pin and rotate the jack into the travel position. Make sure the locking pin snaps into place.
2. Connect any trailer wiring to the tow vehicle. Check for proper operation of the stop and signal lights.
3. Make sure all doors are closed and secure.
4. Check for proper inflation of the trailer tires. Maximum tire pressures can be found on pages 8 - 13.
5. Check the wheel lugs. Tighten or replace any that are loose or missing. If a tire has been removed for axle service or replaced, tighten the lugs in the order shown to the following specifications:
 - A. Start all lug nuts by hand.
 - B. First pass tighten to 20-25 Ft-Lbs (27-33 Nm).
 - C. Second pass tighten to 50-60 Ft-Lbs (67-81 Nm).
 - D. Third pass tighten to 90-120 Ft-Lbs (122-162 Nm).

Note: After the first road use, re-torque the lug nuts in sequence.

6. Maximum recommended speed for highway towing is 45 mph. Recommended off-road towing speed is not to exceed 10 mph or less depending on terrain.

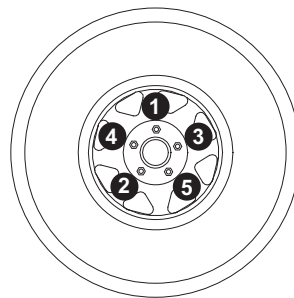

5-Stud Sequence

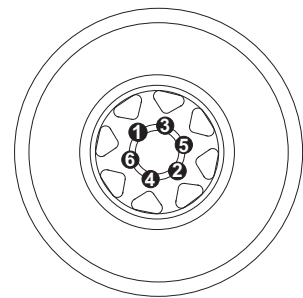

6-Stud Sequence

TRAILER WHEEL BEARINGS

Some trailers are equipped with a grease zerk fitting to allow lubrication of the wheel bearings without the need to disassemble the axle hub. To lubricate the axle bearings, remove the small rubber plug on the grease cap, attach a standard grease gun fitting to the grease zerk fitting and pump grease into the fitting until new grease is visible around the nozzle of the grease gun. Use only a high quality grease made specifically for lubrication of wheel bearings. Wipe any excess grease from the hub with a clean cloth and replace the rubber plug when finished. The minimum recommended lubrication is every 12 months or 12,000 miles; more frequent lubrication may be required under extremely dusty or damp operating conditions.

AUXILIARY FUEL TANK OPTION

The auxiliary fuel tank option is designed so the unit can run from an external fuel tank. The unit is still programmed to shut down when the internal tank's fuel level drops below five percent. In order for the unit to run off of an auxiliary tank, the fuel level in the internal tank must remain over five percent. To operate the unit using an auxiliary fuel tank, use the following procedure:

1. Shut down the unit and check that the level of fuel in the tank is above five percent.
2. Attach the auxiliary fuel tank's fuel lines to the "AUXILIARY FUEL INLET" and "AUXILIARY FUEL OUTLET" fittings on the unit.
3. Open the "AUXILIARY FUEL INLET" and "AUXILIARY FUEL OUTLET" valves located above the fuel fill cap behind the lift structure.

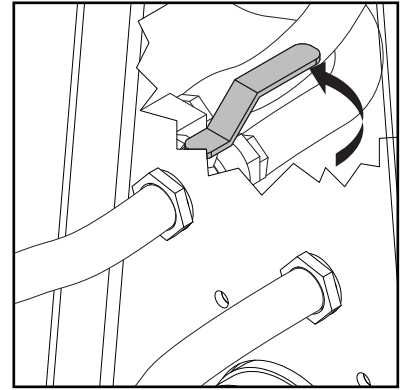

FUEL TRANSFER PUMP OPTION

The fuel transfer pump option allows the fuel tank to be refilled from an external bulk fuel source. When the fuel transfer switch is on, anytime the fuel level drops below 15% the fuel transfer pump will begin pumping fuel from an external bulk fuel source into the fuel tank on the unit. The fuel transfer pump will shut off when the fuel level of the internal tank reaches 90%. The pump will also be monitored to ensure a certain percentage increase in fuel level over a given period of time to prevent the pump from running dry. To operate the fuel transfer system, use the following procedure:

1. Shut down the unit. **Note:** if the external bulk fuel supply is already connected, the unit does not have to be shut down to turn the fuel transfer pump option on or off.
2. Attach the external bulk fuel supply to "FUEL TRANSFER INLET" fitting on the unit.
3. Turn on the Fuel Transfer Switch.

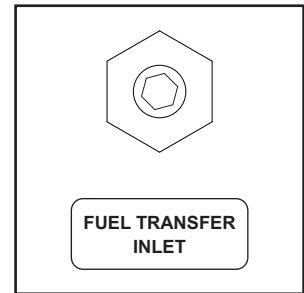

CHECKING GENERATOR DRIVE PLATE TORQUE

Follow the procedure below to check the torque of the generator drive plate bolts in accordance with the maintenance chart on page 43.

1. Remove the generator fan guard.
2. Torque each of the drive plate bolts to the appropriate specification shown in the table below.

Unit	FT/LB
MMG25FHI	36
MMG35FH	41
MMG35FHP	36

Unit	FT/LB
MMG45FHK	41
MMG50FHP	31
MMG55FH	41

3. Reinstall the generator fan guard.

TRAILER WIRING DIAGRAM

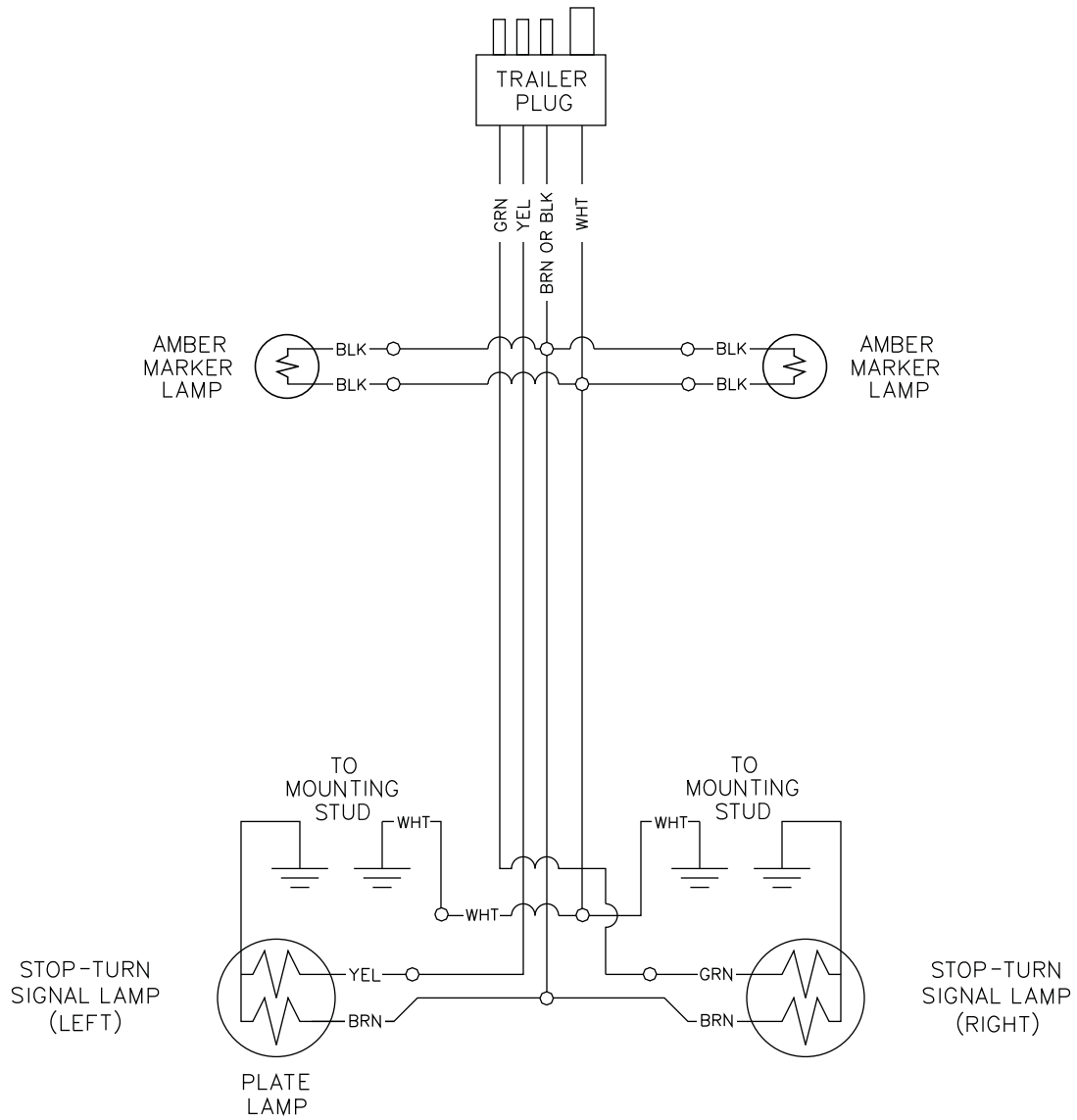

ELECTRIC BRAKE WIRING HARNESS

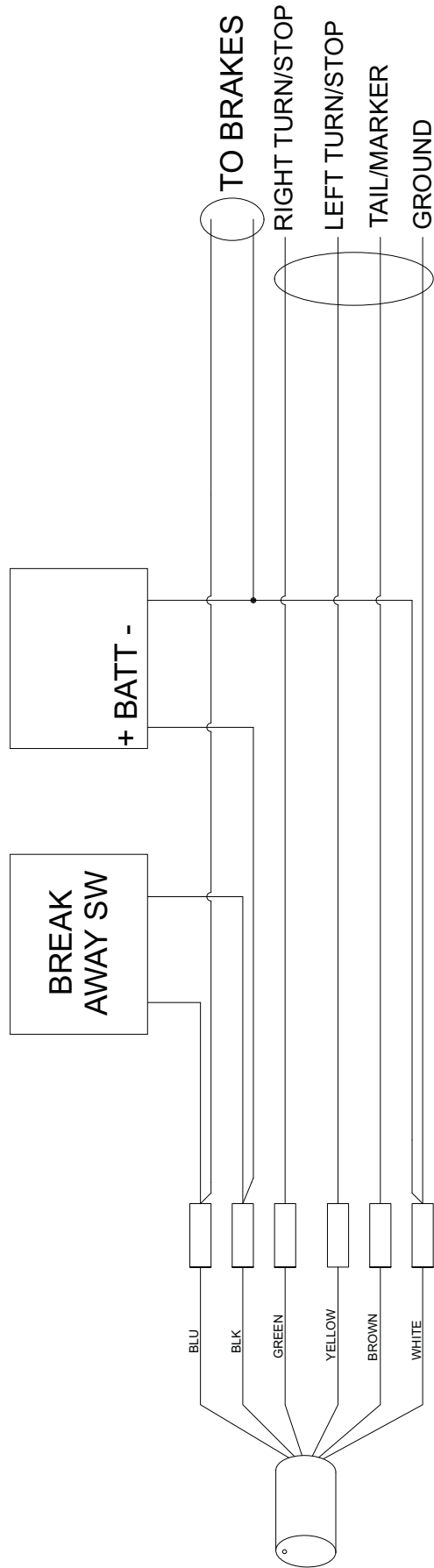

AC WIRING DIAGRAM

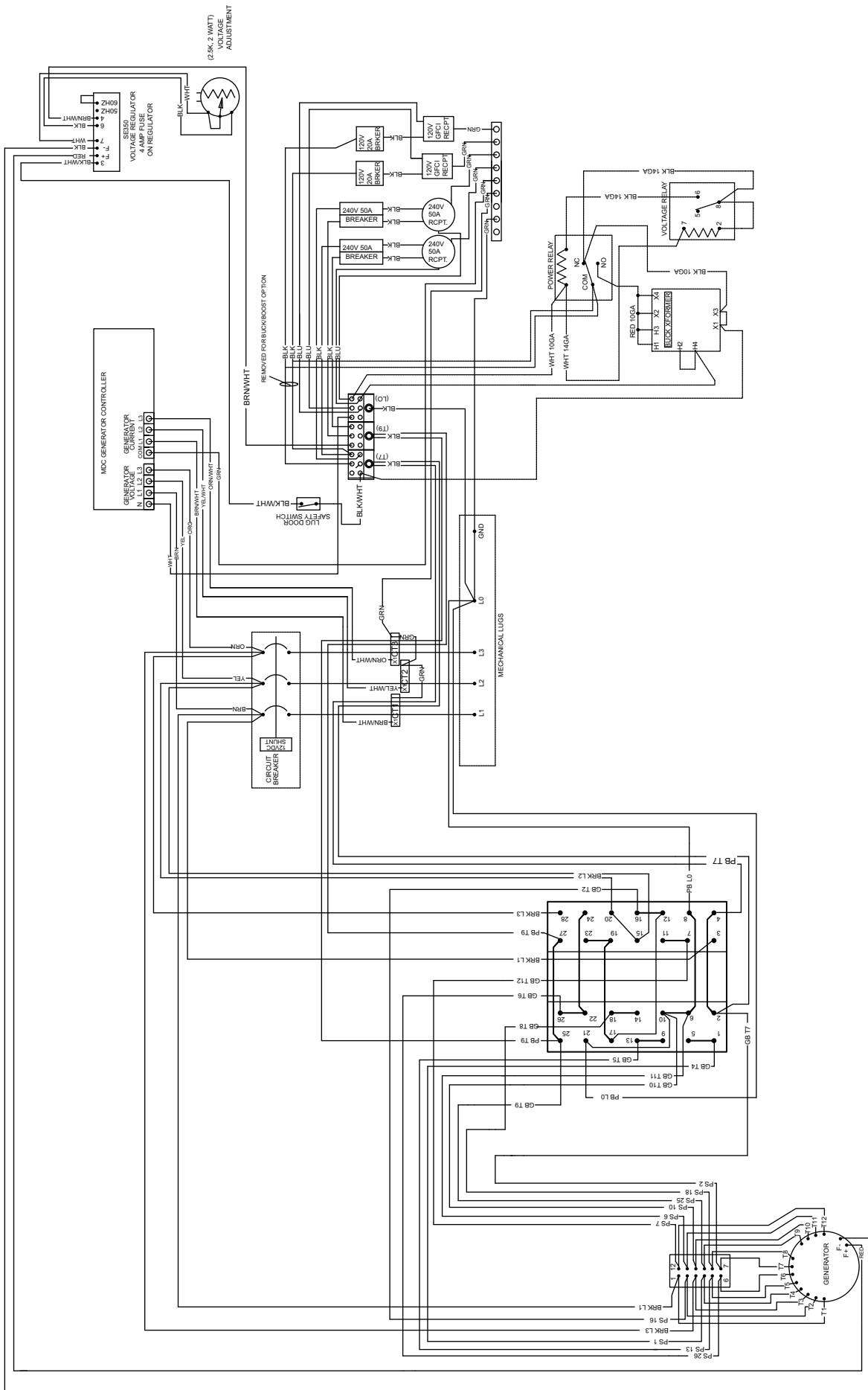

AC WIRING DIAGRAM: MMG45FHK

After Serial Number 0800545

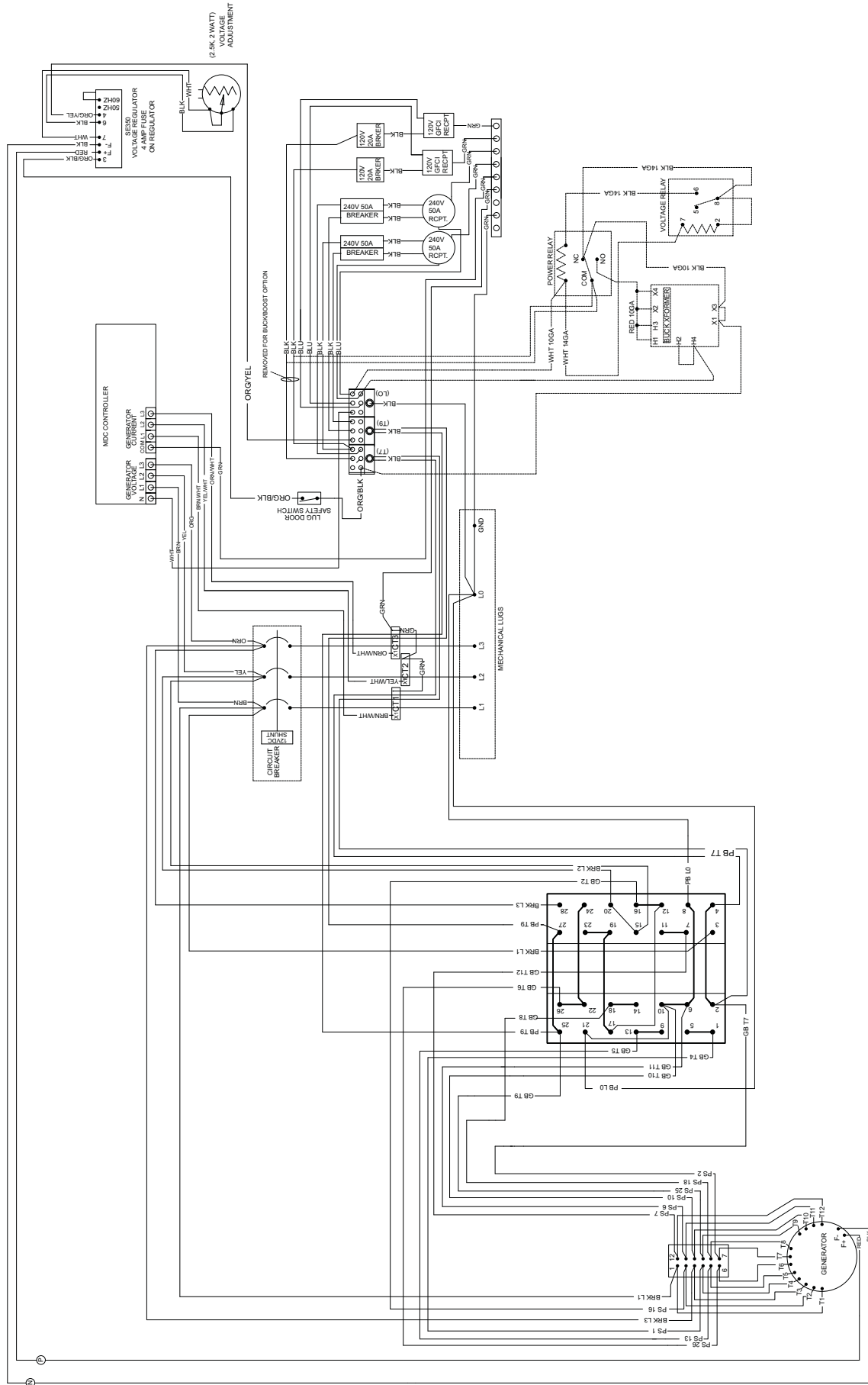

AC WIRING DIAGRAM: 4-POSITION VOLTAGE SELECTOR SWITCH

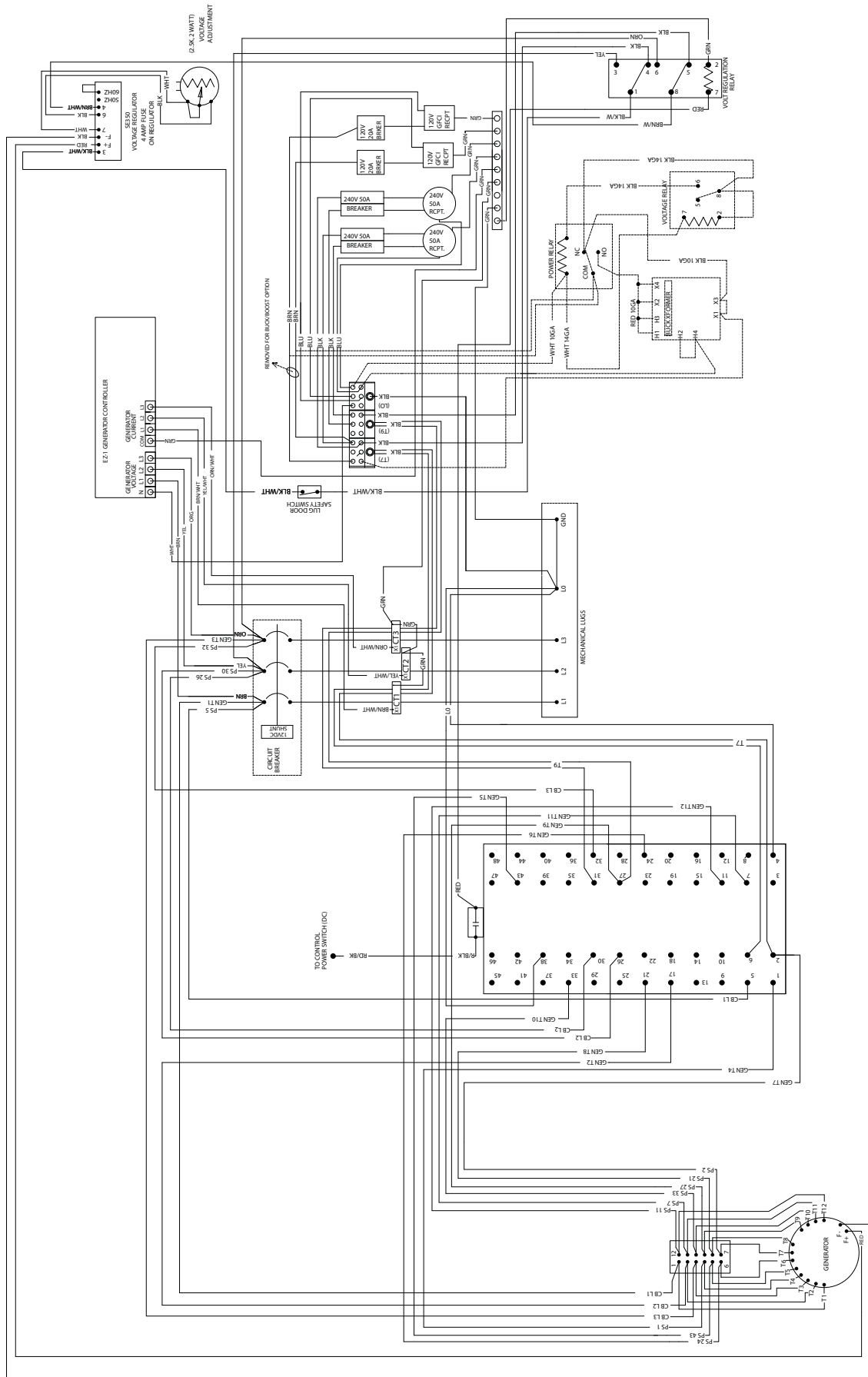

DC WIRING DIAGRAM - JOHN DEERE

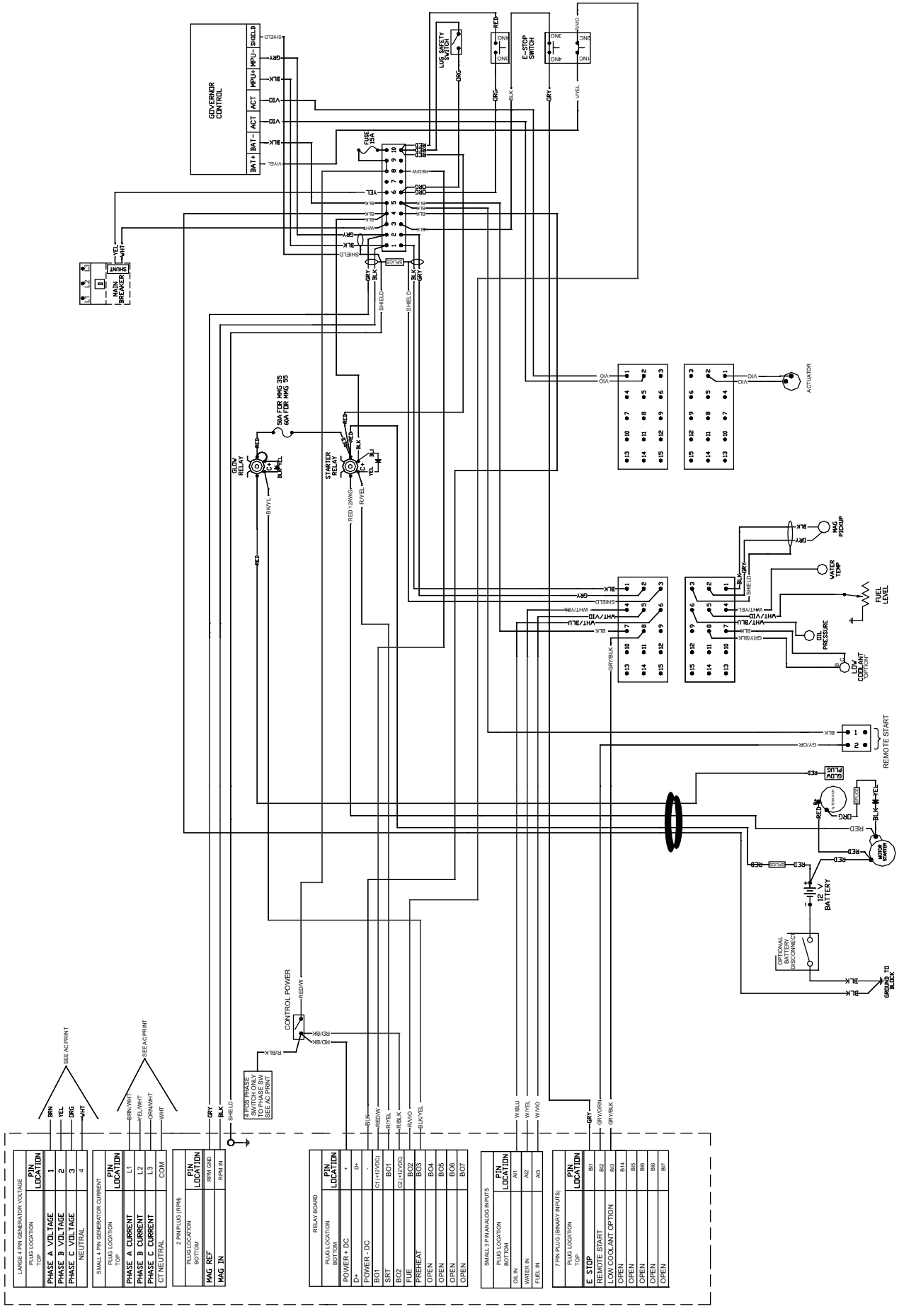

LARGE 4 PIN GENERATOR VOLTAGE	
PLUS LOCATION	PIN LOCATION
TOP	1
PHASE A VOLTAGE	2
PHASE B VOLTAGE	3
PHASE C VOLTAGE	4
NEUTRAL	

SEE AC PRINT

SMALL 4 PIN GENERATOR CURRENT	
PLUS LOCATION	PIN LOCATION
TOP	L1
PHASE A CURRENT	L2
PHASE B CURRENT	L3
PHASE C CURRENT	
CT NEUTRAL	COM

SEE AC PRINT

2 PIN PLUG (RPM)	
PLUS LOCATION	PIN LOCATION
BOTTOM	RPM GND
MAG REF	RPM IN
MAG IN	

RELAY BOARD	
PLUS LOCATION	PIN LOCATION
BOTTOM	D+
POWER + DC	
D+	
POWER - DC	CI (+12VDC)
BOT	CI (-12VDC)
SRT	BOZ
BOT	BOZ
PREHEAT	BOZ
OPEN	BOZ
OPEN	BOZ
OPEN	BOZ
OPEN	BOZ

SMALL 7 PIN PLUG (BINARY INPUTS)	
PLUS LOCATION	PIN LOCATION
BOTTOM	AI1
OIL IN	AI2
WATER IN	AI3
FUEL IN	

7 PIN PLUG (BINARY INPUTS)	
PLUS LOCATION	PIN LOCATION
BOTTOM	E STOP
REMOTE START	
LOW COOLANT OPTION	
OPEN	
OPEN	
OPEN	
OPEN	

MDC CONTROLLER

DC WIRING DIAGRAM - PERKINS

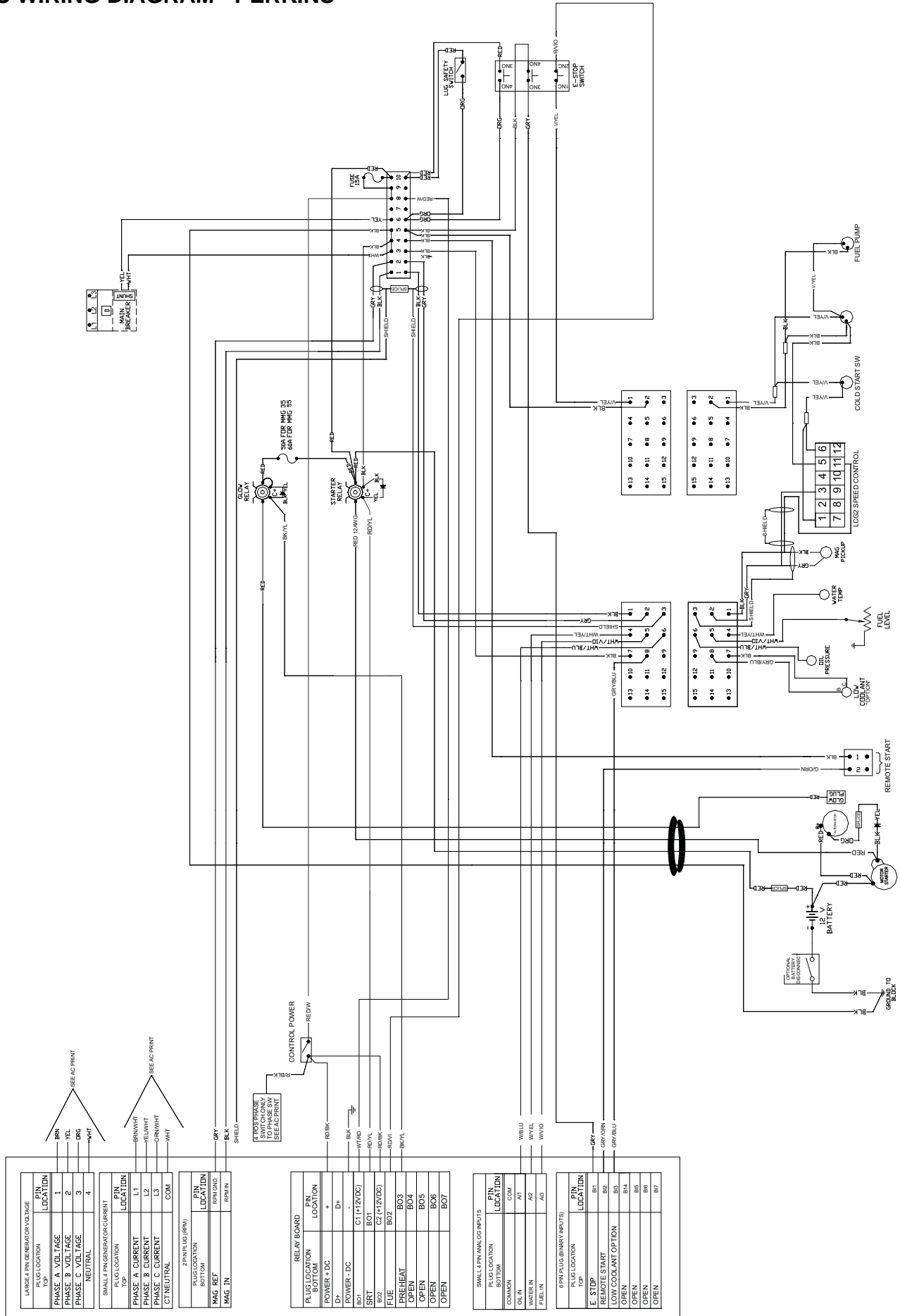

LARGE 4 PIN GENERATOR VOLTAGE	PIN LOCATION
PHASE A VOLTAGE	1
PHASE B VOLTAGE	2
PHASE C VOLTAGE	3
NEUTRAL	4

SMALL 4 PIN GENERATOR CURRENT	PIN LOCATION
PHASE A CURRENT	L1
PHASE B CURRENT	L2
PHASE C CURRENT	L3
CT NEUTRAL	COM

2 PIN FLUG (RPM)	PIN LOCATION
MAG REF	RPM IN
MAG IN	RPM IN

RELAY BOARD	PIN LOCATION
POWER +DC	D+
POWER -DC	D-
SRT	BO1
FUE	BO2
PREHEAT	BO3
OPEN	BO4
OPEN	BO5
OPEN	BO6
OPEN	BO7

SMALL 4 PIN ANALOG INPUTS	PIN LOCATION
COMMON	COM
OLE IN	AS1
INTERIN	AS2
FUEL IN	AS3

6 PIN FLUG (BINARY INPUTS)	PIN LOCATION
E STOP	B1
REMOTE START	B2
LOW COOLANT OPTION	B3
OPEN	B4
OPEN	B5
OPEN	B6
OPEN	B7

DC WIRING DIAGRAM - KUBOTA, ISUZU

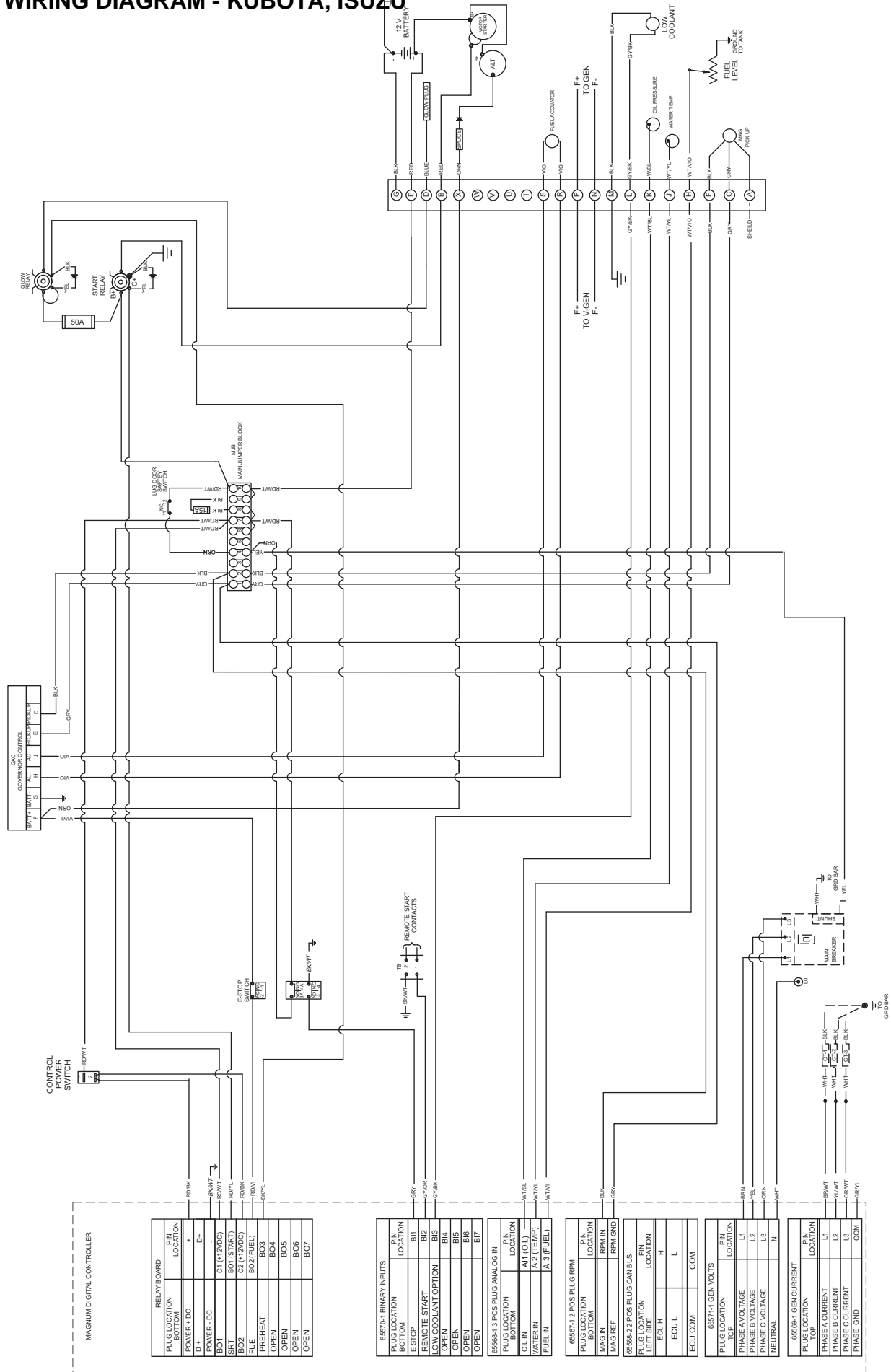

SERVICE LOG

OIL GRADE AND TYPE: _____ BRAND: _____

COOLANT MIXTURE: _____ BRAND: _____

Date	Hours to service	Oil level	Coolant level

Date	Hours to service	Oil level	Coolant level

REV: J
PART NO: 24594
02.18.10